

Hardmetric Connectors
for Backplane-Systems

HM2.0 •

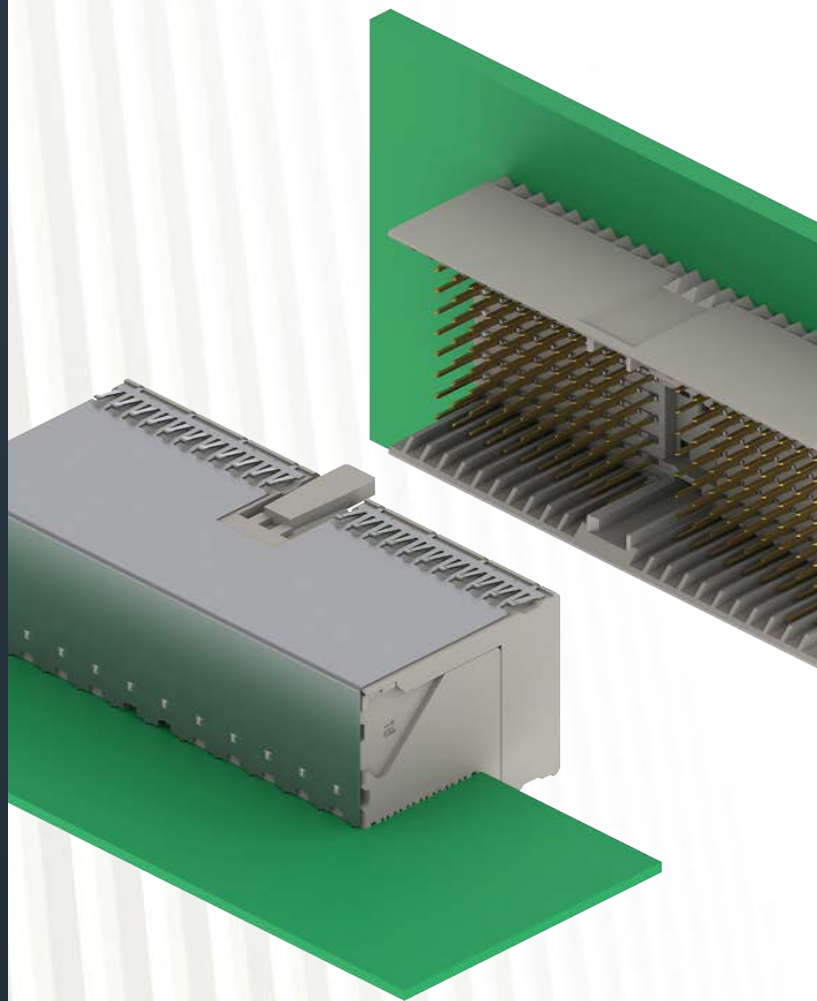

Hardmetric Connectors: hm2.0 for Backplane-Systems



Introduction	4
Overview	6
The Standard / High-Speed	8
System Modularity	9
Overview: CompactPCI	10
Technical Specifications	12
Electrical Characteristics	14
Cross-Talk	15
Hole Specifications	16
Pin Lengths	17
hm2.0 Type A	18
hm2.0 Type B25	22
hm2.0 Type B22	26
hm2.0 Type B19	30
hm2.0 Type AB25	34
hm2.0 Type AB22	38
hm2.0 Type AB19	42
hm2.0 Type C	46
hm2.0 Type D	50
hm2.0 Type E	54
hm2.0 Type DE	58
hm2.0 Type F	62
hm2.0 Type L	66
hm2.0 Type M	68
hm2.0 Type N	72
Accessories: Shroud	74
Accessories: Coding Keys	76
Notes	77

Hardmetric Connectors for Backplane-Systems

High Contact Density

The hm2.0 series of hard metric connectors was developed in accordance with the international IEC 61076-4-101 standard. These shielded connectors have a pitch of 2 mm and are suitable for applications that require high contact density and reliability. Standardization ensures that the connectors are compatible with products from different manufacturers.

hm2.0 connectors are used in CompactPCI, a PICMG standard for high-end systems in 19-inch technology with passive backplanes for high requirements as regards of performance, robustness, and reliability. hm2.0 connectors are also increasingly being used for industrial applications that require a robust connection system with high contact density.

Key Features:

- wide selection of types
- modular connectors with a pitch of 2 mm
- 5 or 8 signal rows
- 12 different pin lengths
- customized assembly layout as an option
- available with or without shielding
- supports a data transfer rate of up to 3.125 Gbit/s
- robust design
- accessories such as shrouds and coding keys

Applications:

- telecommunications
- network systems
- CompactPCI
- medical technology
- industrial PC (IPC)

Termination



Press-fit

Mating Configuration



Perpendicular

CompactPCI™

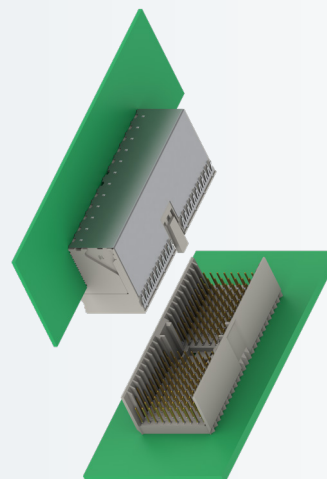
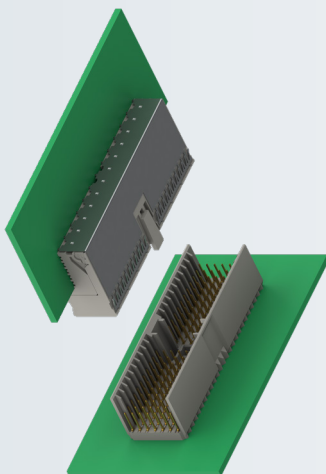



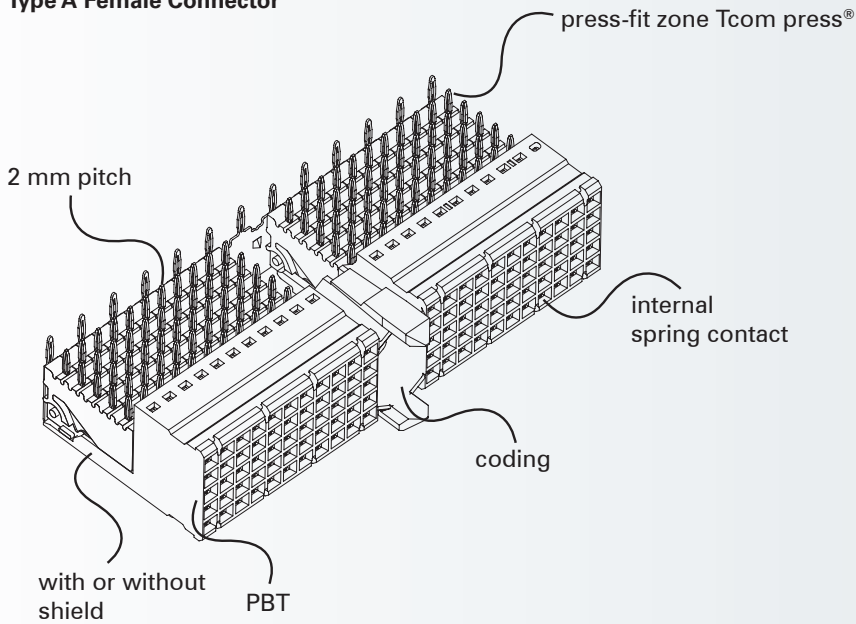



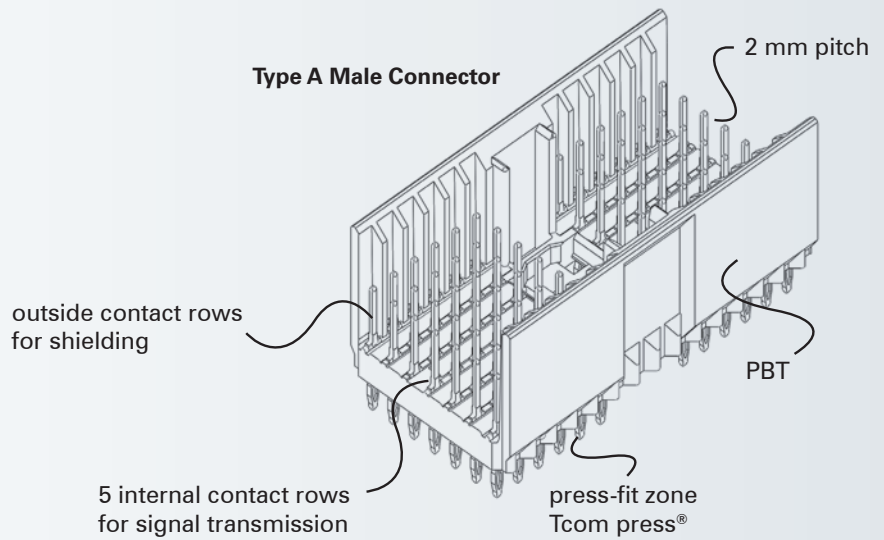



Type A Female Connector

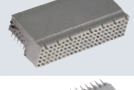
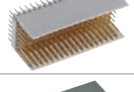
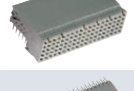
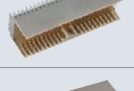
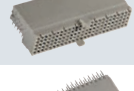

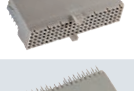
Type A Male Connector

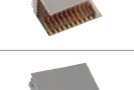

	Type		max. no. of contacts	Backplane or Daughtercard	Mating connector	Page reference
A		A Male connector	154	Backplane 5+2-row	A Female connector	start on p. 18
		A Female connector	110	Daughtercard 5+2-row	A Male connector	
B25		B25 Male connector	175	Backplane 5+2-row	B25 Female connector	start on p. 22
		B25 Female connector	125	Daughtercard 5+2-row	B25 Male connector	
B22		B22 Male connector	154	Backplane 5+2-row	B22 Female connector	start on p. 26
		B22 Female connector	110	Daughtercard 5+2-row	B22 Male connector	
B19		B19 Male connector	133	Backplane 5+2-row	B19 Female connector	start on p. 30
		B19 Female connector	95	Daughtercard 5+2-row	B19 Male connector	
AB25		AB25 Male connector	169	Backplane 5+2-row	AB25 Female connector	start on p. 34
		AB25 Female connector	125	Daughtercard 5+2-row	AB25 Male connector	
AB22		AB22 Male connector	146	Backplane 5+2-row	AB22 Female connector	start on p. 38
		AB22 Female connector	110	Daughtercard 5+2-row	AB22 Male connector	
AB19		AB19 Male connector	127	Backplane 5+2-row	AB19 Female connector	start on p. 42
		AB19 Female connector	95	Daughtercard 5+2-row	AB19 Male connector	
C		C Male connector	77	Backplane 5+2-row	C Female connector	start on p. 46
		C Female connector	55	Daughtercard 5+2-row	C Male connector	

	Type		max. no. of contacts	Backplane or Daughtercard	Mating connector	Page reference
D		D Male connector	220	Backplane 8+2-row	D Female connector	start on p. 50
		D Female connector	176	Daughtercard 8+2-row	D Male connector	
E		E Male connector	250	Backplane 8+2-row	E Female connector	start on p. 54
		E Female connector	200	Daughtercard 8+2-row	E Male connector	
DE		DE Male connector	244	Backplane 8+2-row	DE Female connector	start on p. 58
		DE Female connector	200	Daughtercard 8+2-row	DE Male connector	
F		F Male connector	110	Backplane 8+2-row	F Female connector	start on p. 62
		F Female connector	88	Daughtercard 8+2-row	F Male connector	
L		L Male connector	6	Backplane	L Female connector	start on p. 66
		L Female connector	6	Daughtercard	L Male connector	
M		M Male connector	77+3	Backplane 5+2-row	M Female connector	start on p. 68
		M Female connector	55+3	Daughtercard 5+2-row	M Male connector	
N		N Male connector	3	Backplane	N Female connector	start on p. 72
		N Female connector	3	Daughtercard	N Male connector	
Shroud		A, B, B22, B19, C	-	-	-	start on p. 74
		AB25, AB22, AB19	-	-	-	
Coding		Coding keys	-	-	-	S. 76

The Standard IEC 61076-4-101

The hardmetric connector system ept hm2.0 was developed and manufactured according to the international standard IEC 61076-4-101. Thus the user can rely on a worldwide standard for the connection of printed circuit boards using connectors with a large number of contacts. The printed circuit boards can be exchanged between systems without difficulty. Important parameters such as the fixing, shielding and coding of the printed circuit boards are compatible regardless of the individual application.

ept hm2.0 connectors are designed with a 2 mm metric grid. They can be easily connected in series to form a continuous 2 mm grid. This grid pattern is advantageous when creating a printed circuit board since no space is lost in the individual connector modules.

The modules A, D, L and M are equipped with a multi-function block. This in turn can be equipped with the

coding keys. The molded guides ensure the correct alignment of the male and female connectors to each other and they offer anti-twist protection before contacting.

The coding keys can be inserted or withdrawn using a simple insertion or withdrawal tool.

ept offers three different lengths for the front and four different lengths for the rear side. The different contact lengths are necessary because certain signal or ground contacts need to be the first to be connected/disconnected when adding/removing a module.

The 11.25 mm long contacts are mainly required for the shielding rows z and f.

The ends of the insulator material are chamfered to simplify the connection of additional modules and avoid twisting the connectors. The chamfers ensure the exact positioning on the printed circuit boards and stabilize the modules.



The connectors must be coded in a modern BUS system to avoid mixing up the printed circuit boards.

The possibility of coding has already been defined in the IEC 61076-4-101. "Coding keys" can be manually snapped onto the multi-function block of the connector types A, D, L and M. The different inserts are color-coded and can thus be kept apart.



hm2.0 for High-Speed Applications

High-speed applications can be realized with hm2.0 connectors from ept. It was possible to attain data transfer rates of up to 3.125 Gbps under the framework conditions described below.

- two hm2.0 connector pairs from ept
- two standard FR4 PCBs at a thickness of 1.6 mm and a PCB track length of 115 mm
- one standard FR4 backplane at a thickness of 4.4 mm and a PCB track length of 400 mm
- special attention is paid to connection interruptions, the stub effect, the skin effect, and dielectric losses in the application design

We would be happy to provide you with more details and the corresponding technical literature on high-speed applications using hm2.0 connectors. Get in touch with us.

System Modularity

ept hm2.0 modules offer a number of possibilities to optimize large contact densities, especially in combination with coaxial or fiber-optic connections.

Using module type A, connections with a length of 50 mm can be set up in increments of 25 mm to achieve an overall length as required.

The connectors with a multifunction block (types A, M, L) are preferably arranged at the beginning of a connector row. The type B module on the other hand is only arranged between other modules.

Due to their inverse-polarity protection the 25 mm type C and N modules are arranged at the end of a connector row. The coding keys in the multifunction block and the modules type C and N ensure that the modules are plugged in correctly.

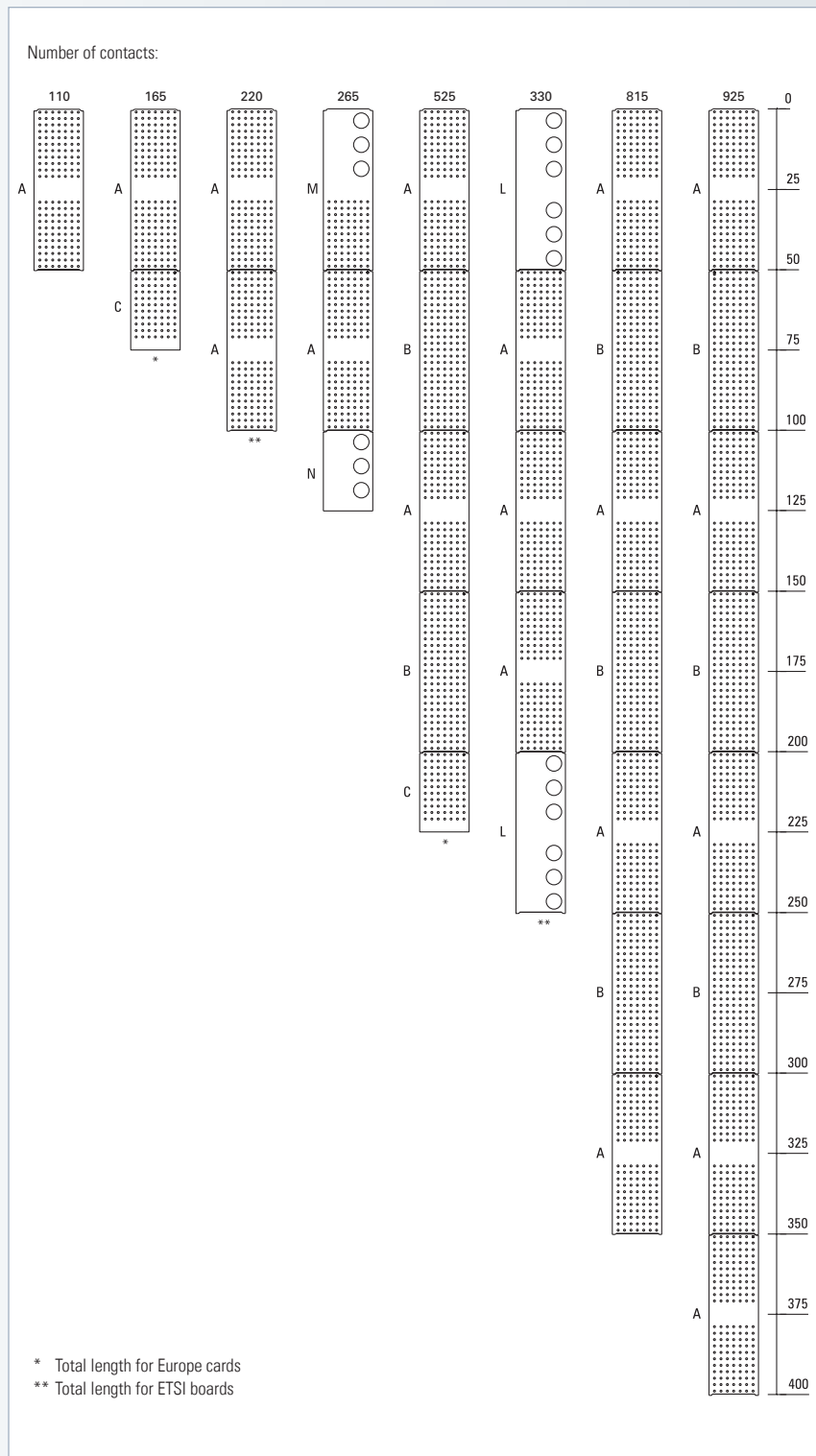

Overview CompactPCI Connectors

CompactPCI as the PICMG standard places high requirements on 19-inch high-end systems with passive backplanes as regards robustness, reliability, and performance. CompactPCI platforms are cost optimized, scalable, suitable for harsh environmental conditions, and highly durable. This is why system designers rely on robust, modular, standard-compliant CompactPCI platforms. The PICMG® standards for CompactPCI provide specifications for hard metric connectors. ept's hm2.0 connectors are optimally suited for use in CompactPCI applications.

Female connectors for daughter card	Location	Shielding	Part number	PU (Tray)
Typ A	J1/rJ1/J4/rJ4	top	244-11300-15	35/140
Typ B22	J2/J5	top	244-22300-15	
Typ AB22*	rJ2/rJ5	top	244-62300-15	
Typ B19	J3	top	244-23300-15	42/168
Typ AB19*	rJ3	top	244-63300-15	35/140
Typ A für telephony	J4	divided	244-11305-15	
Typ A für telephony (mirrored)	rJ4	divided	244-11306-15	

* For rear transition card applications the AB connectors are used with AB shroud. All connectors are also available without shield.

Male connectors for backplanes	Position	Contact arrangement*	Part number	PU (Tube)
Type A Hot Swap	P1	CB***BC	243-11322-15	10/240
Type A Hot Swap for Midplane	P1	TP***PT	243-11710-15F	
Type B22	P2	CBBBBBC	243-22320-15	11/264
Type B22 AB compatible	P2/P5	*PPPPP*	243-22361-15F	
Type B22 AB compatible	P2/P5	*NNNNN*	243-22734-15F	
Type B22 AB compatible	P2/P5	*SSSSS*	243-22371-15F	13/312
Type B19	P3	CBBBBBC	243-23320-15	
Type B19 AB compatible	P3	*PPPPP*	243-23361-15F	
Type B19 AB compatible	P3	*NNNNN*	243-23716-15F	
Type B19 AB compatible	P3	*SSSSS*	243-23371-15F	10/240
Type A for telephony	P4	—*****	243-11323-15	
Type A for telephony Midplane	P4	—*****	243-11709-15F	
Type A	P4	TPPPPPT	243-11360-15F	
Type A	P4	TNNNNNT	243-11734-15F	
Type A	P4	TSSSSST	243-11715-15F	11/264
Type B22 for telephony	P5	C*****C	243-22311-15	
Type B22 for telephony, row Z not loaded	P5	—*****C	243-22312-15	
Type B22 for telephony, row Z not loaded	P5	—*****	243-22351-15F	

* Different pin lengths in this row.

All connectors are also available with row Z unloaded/for other contact arrangements, please contact ept.

Coding keys	Color	Application	Part number	PU (Bulk)
Male connector backplane	Brilliant blue	5 V – P1	243-8014	1000
Male connector backplane	Cadmium yellow	3.3 V – P1	243-8031	
Male connector backplane	Strawberry red	Telephony – P4	243-8012	
Female connector daughter card	Brilliant blue	5 V – J1	244-8014	
Female connector daughter card	Cadmium yellow	3.3 V – J1	244-8031	
Female connector daughter card	Strawberry red	Telephony – J4	244-8012	

Shroud	Position	Height	Base height	PCB thickness	Part number	PU (Bulk)
Type A	P1/P4	16.75 mm	6.3 mm	< 2.4 mm	243-5525-5/1	750
Type A	P1/P4	15.35 mm	4.9 mm	2.4 – 3.2 mm	243-5525-4/1	
Type A	P1/P4	14.95 mm	4.5 mm	3.2 – 4.0 mm	243-5525-1/1	
Type A	P1/P4	14.15 mm	3.7 mm	4.0 – 4.8 mm	243-5525-2/1	
Type A	P1/P4	13.35 mm	2.9 mm	> 4.8 mm	243-5525-3/1	
Type AB22	P2/P5	16.75 mm	6.3 mm	< 2.4 mm	243-5722-5/1	850
Type AB22	P2/P5	15.35 mm	4.9 mm	2.4 – 3.2 mm	243-5722-4/1	
Type AB22	P2/P5	14.95 mm	4.5 mm	3.2 – 4.0 mm	243-5722-1/1	
Type AB22	P2/P5	14.15 mm	3.7 mm	4.0 – 4.8 mm	243-5722-2/1	
Type AB22	P2/P5	13.35 mm	2.9 mm	> 4.8 mm	243-5722-3/1	
Type AB19	P3	16.75 mm	6.3 mm	< 2.4 mm	243-5719-5/1	1000
Type AB19	P3	15.35 mm	4.9 mm	2.4 – 3.2 mm	243-5719-4/1	
Type AB19	P3	14.95 mm	4.5 mm	3.2 – 4.0 mm	243-5719-1/1	
Type AB19	P3	14.15 mm	3.7 mm	4.0 – 4.8 mm	243-5719-2/1	
Type AB19	P3	13.35 mm	2.9 mm	> 4.8 mm	243-5719-3/1	

The height/bottom thickness of the shroud depends on the thickness of the backplane.

Technical Specifications

Technical Specifications	hm2.0	
	Testing Standard	Connectors according to IEC 61076-4-101
Basics		
Standard		IEC 61076-4-101
Number of contacts		55 to 250
Termination		Press-fit
Operating temperature range		-55°C to +125°C
Material		
Insulator material		PBT glass filled
Contact material		Bronze
Mechanical		
Pitch		2 mm
Mating force per pin		Contact: max. 0.75 N, Shielding: max. 1 N
Separating force per pin		Contact: min. 0.15 N, Shielding: min. 0.15 N
Durability	IEC 60512-9-1:2010	Performance level II = 250 mating cycles
Electrical		
Operational current	IEC 60512-5-2:2002	1.5 A @ +20°C, 1.0 A @ +70°C
Contact resistance	IEC 60512-2-1:2002	max. 20 mΩ
Clearance and creepage		min. 0.6 Female connector, min. 0.8 mm Male connector
Insulation resistance	IEC 60512-3-1:2002	min. 10 ⁴ MΩ
Test voltage	IEC 60512-4-1:2003	750 V r. m. s.
Data transfer rate		up to 3.125 Gbit
Processing		
Packaging		Male connectors: Tube; Female connectors: Tray
Approval		
Flammability		UL (file: E130314)
Environment		RoHS compliant

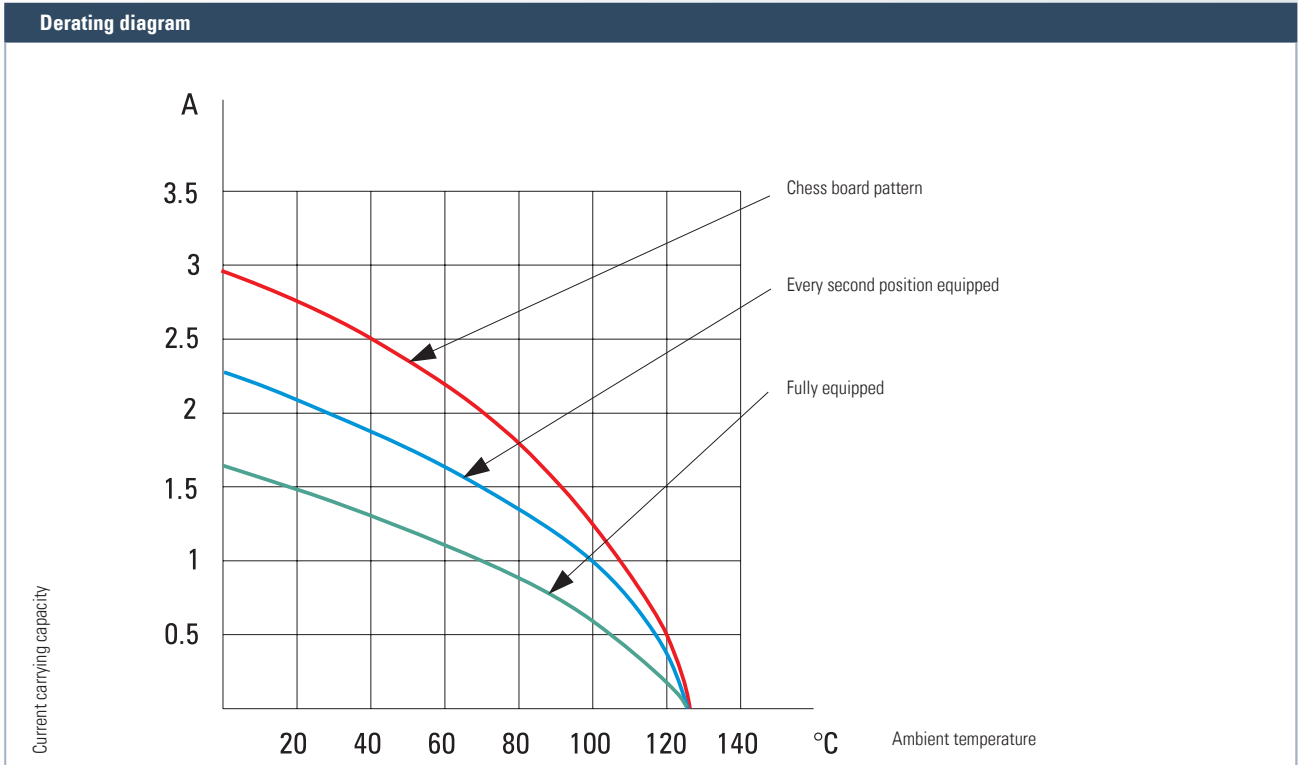

Test voltage		Fully loaded	every second position	Chessboard
Rows a, c, e Rows b, d	within the row	750 V _{r.m.s}	1500 V _{r.m.s}	–
	between the rows	1500 V _{r.m.s}	1500 V _{r.m.s}	–
Rows a, b, c Rows a, b, c, d Rows a, b, c, d, e	within the rows	750 V _{r.m.s}	1500 V _{r.m.s}	1500 V _{r.m.s}
	between the rows	750 V _{r.m.s}	750 V _{r.m.s}	1200 V _{r.m.s}

Creepages and clearances according to IEC 61076-4-101		Fully loaded		every second position		Chessboard	
		Backplane Male connector	Module Female connector	Backplane Male connector	Module Female connector	Backplane Male connector	Module Female connector
Rows a, c, e Rows b, d	within the row	0.8 mm	0.6 mm	2.5 mm	2.5 mm	–	–
	between the row	2.5 mm	2.5 mm	2.5 mm	2.5 mm	–	–
Rows a, b, c Rows a, b, c, d Rows a, b, c, d, e	within the row	0.8 mm	0.6 mm	2.5 mm	2.5 mm	2.5 mm	2.5 mm
	between the row	0.8 mm	0.6 mm	0.8 mm	0.6 mm	1.2 mm	1.5 mm

Electrical Characteristics

The connector system ept hm2.0 has been especially developed for high data rates. Below some HF characteristics are described as example.

A SPICE model is available for simulation when developing systems. The simulation model was verified by means of TDR measurements.

Impedance gradient along a pin in row d

Impedance measured after eliminating multiple reflection

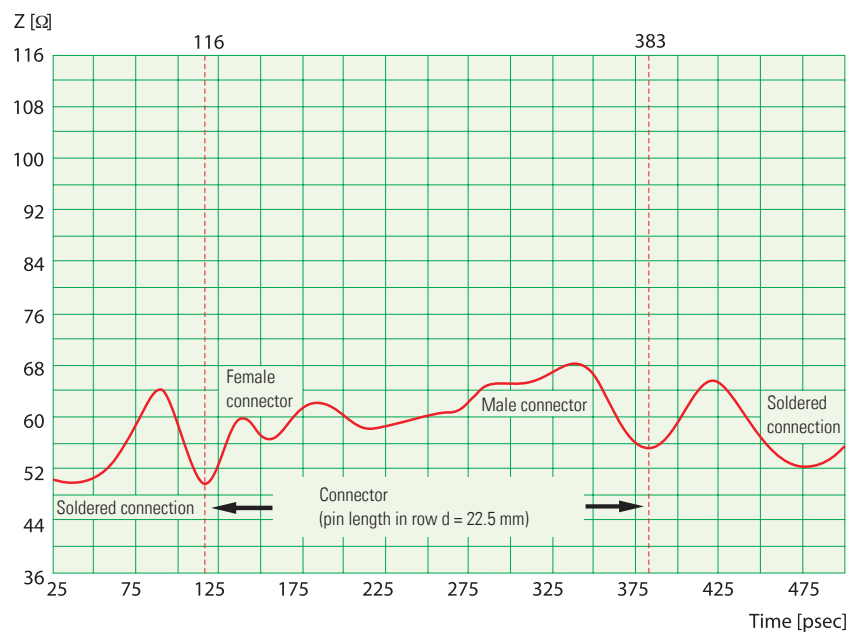

$U_{\text{reflect_max}}$ is the maximum reflection of an ept hm2.0 connector in percent, shown as function of the signal rise time. The connector is the only electrical discontinuity in a selected 50 ohm system.

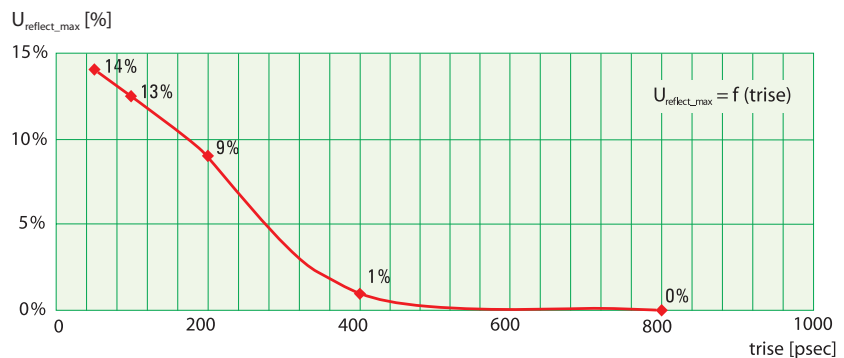

Cross Talk

'Crosstalk' means that independent signal channels are influencing each other in an unwanted manner. This effect is expressed in decibels.

Near end and far end cross talk was measured and simulated for different arrangements. A 200 mV input signal and a signal rise time of 25 psec. were applied.

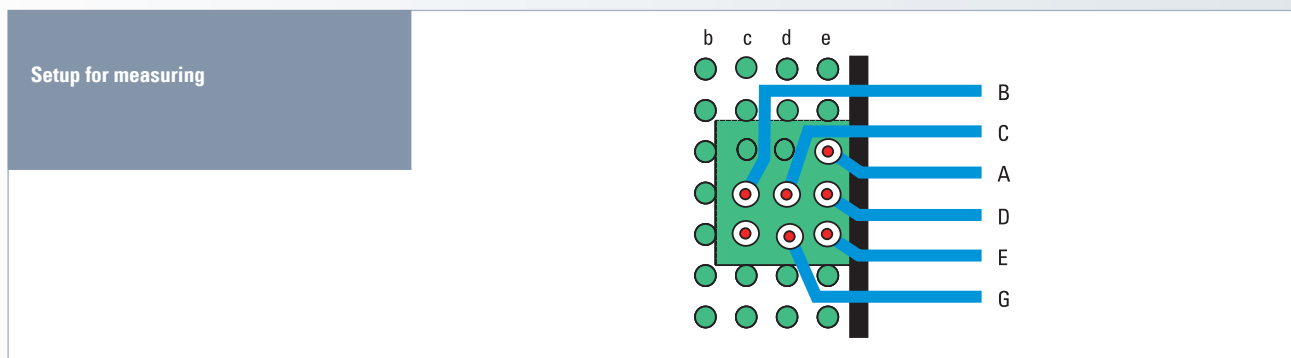
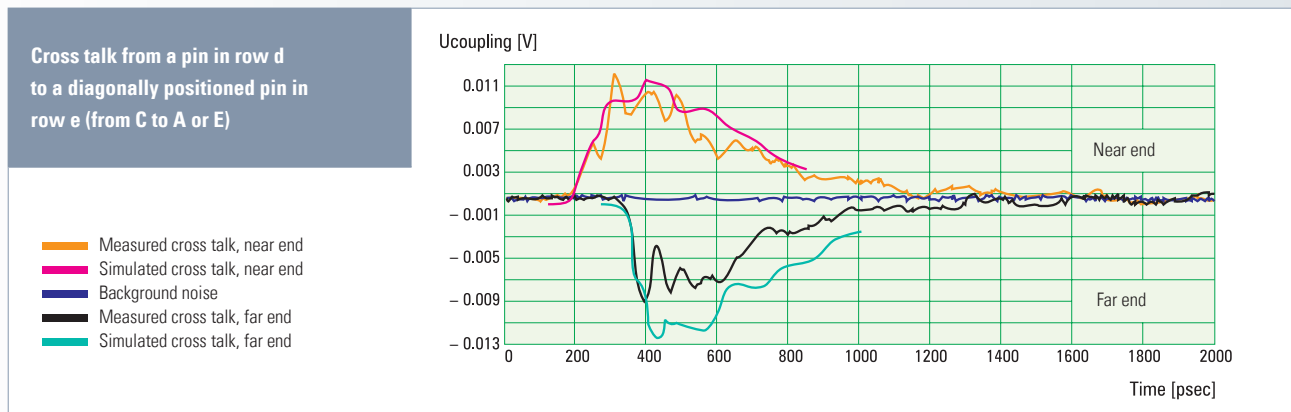
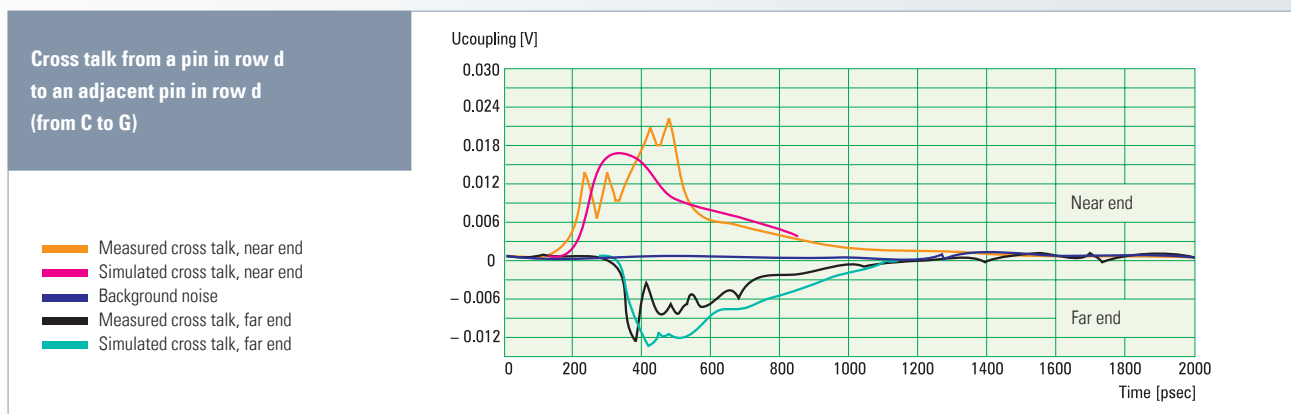

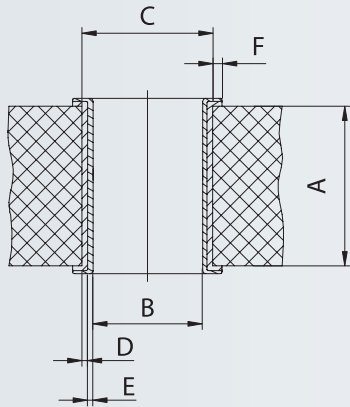

Hole Specifications Press-fit

Plated through-hole according to IEC 60352-5

ept offers adapted press-fit zones for various new board surfaces.

	Nominal hole	Ø 0.6 mm
imm. Sn printed circuit boards		
A	PCB thickness	min. 1.4 mm
B	Plated hole	Ø 0.60 ± 0.05 mm
C	Drill hole	0.70 ± 0.02 mm
D	Cu plating	min. 25 µm
E	imm. Sn plating	max. 1.5 µm
F	Annular ring	min. 0.1 mm
Ni, Au printed circuit boards		
A	PCB thickness	min. 1.4 mm
B	Plated hole	Ø 0.60 ± 0.05 mm
C	Drill hole	0.70 ± 0.02 mm
D	Cu plating	min. 25 µm
E	Ni, Au plating	0.05 – 0.2 µm Au over 2.5 – 5 µm Ni
F	Annular ring	min. 0.1 mm
pure Cu printed circuit boards		
A	PCB thickness	min. 1.4 mm
B	Plated hole	Ø 0.60 ± 0.05 mm
C	Drill hole	0.70 ± 0.02 mm
D	Cu plating	min. 25 µm
E	OSP*	e. g. GLICOAT-SMD (F2) with 0.12 – 0.15 µm
F	Annular ring	min. 0.1 mm
HAL Sn printed circuit boards		
A	PCB thickness	min. 1.4 mm
B	Plated hole	Ø 0.60 ± 0.05 mm
C	Drill hole	0.70 ± 0.02 mm
D	Cu plating	min. 25 µm
E	HAL Sn	5 – 15 µm
F	Annular ring	min. 0.1 mm

* OSP = Organic Solderability Preservatives

Pin Lengths

Dimension drawing	Contact	Connection	Contact length	Use
	A	without rear mating zone	8.25 ± 0.1	Level 1, contact for signal
	B		9.75 ± 0.1	Level 2, contact for signal
	C		11.25 ± 0.1	Level 3, shielding
	K	with rear mating zone 13 mm	8.25 ± 0.1	Level 1, contact for signal
	L		9.75 ± 0.1	Level 2, contact for signal
	M		11.25 ± 0.1	Level 3, shielding
	N	with rear mating zone 14.5 mm	8.25 ± 0.1	Level 1, contact for signal
	P		9.75 ± 0.1	Level 2, contact for signal
	Q		11.25 ± 0.1	Level 3, shielding
	R	with rear mating zone 16 mm	8.25 ± 0.1	Level 1, contact for signal
	S		9.75 ± 0.1	Level 2, contact for signal
	T		11.25 ± 0.1	Level 3, shielding

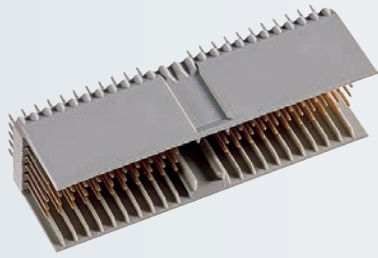

Type: Male connector straight with 5 rows

Termination: Press-fit

Number of contacts: 100, 110, 154

Pitch: 2 mm

Operational current: 1.5 A

Packaging: Tube

Standard: IEC 61076-4-101



Technical Specifications on page 12

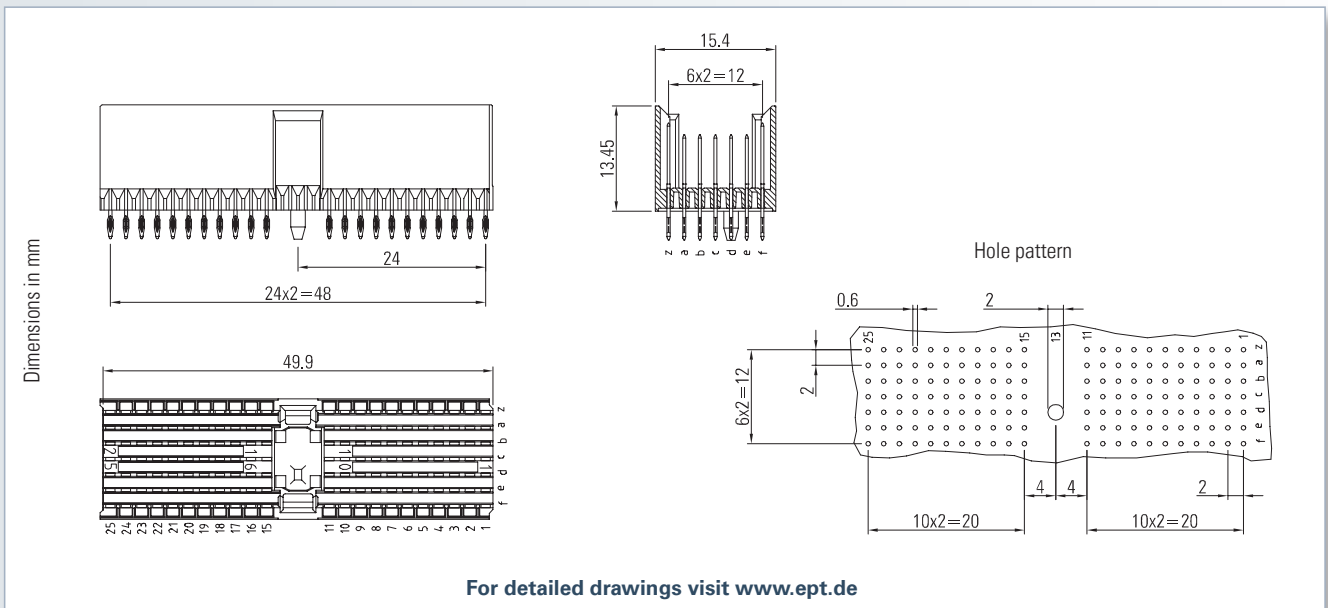

Accessories

- Coding p. 76
- Shroud p. 74

Note

- Pin lengths see p. 17
- CompactPCI P1/P4

Mating connector / Application:



Type A Female connector (p. 20)



Press-fit - Performance level II

No. of contacts	Contact arrangement	PCB thickness >2.2 mm	
		Part number	PU (Tube)
110		243-11010-15	
154		243-11310-15	
154		243-11322-15 cPCI Hot-Swap (P1)	10/240
100		243-11323-15 cPCI Telephony Spec (P4)	
154		243-11360-15F	

On request

- contact arrangement
- other contact surface

Ordering note

- PCB thickness 1.4 - 2.2 mm
(Part number 243-11xxx-05)

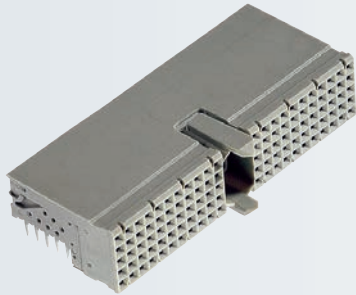

Type: Female connector 90° with 5 rows

Termination: Press-fit

Number of contacts: 90, 110

Pitch: 2 mm

Operational current: 1.5 A

Packaging: Tray

Standard: IEC 61076-4-101



Technical Specifications on page 12

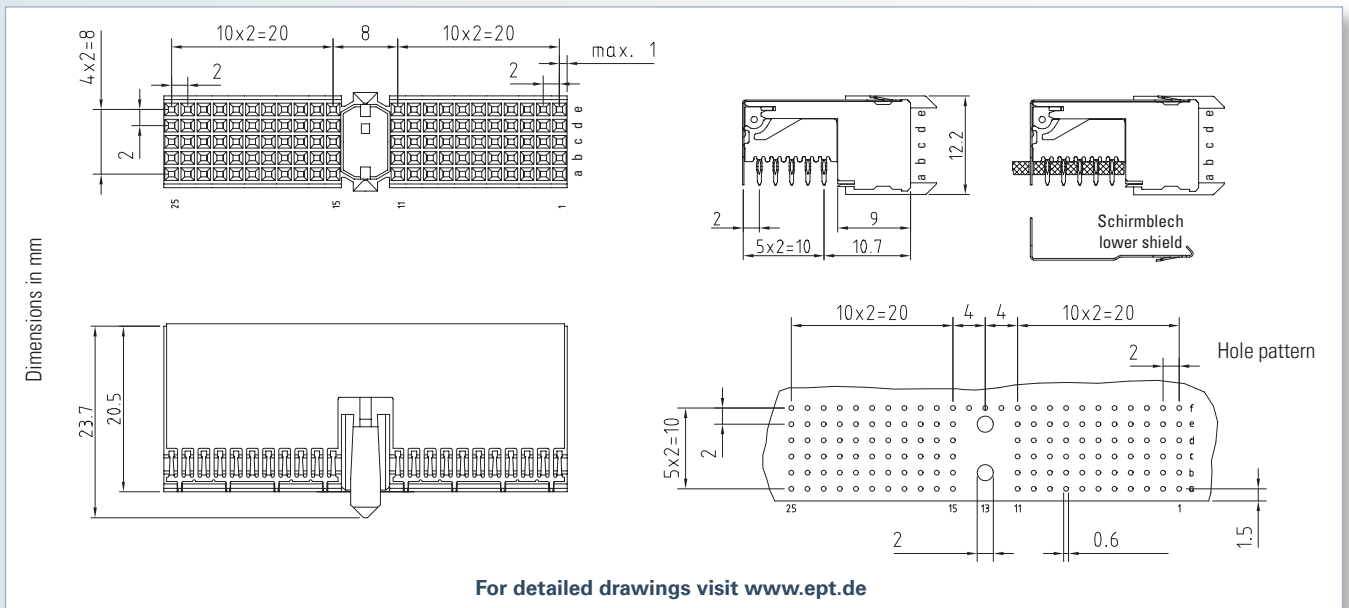

Accessories

- Coding p. 76

Note

- CompactPCI J1/J4

Mating connector / Application:



Type A Male connector (p. 18)



Press-fit - Performance level II •••

No. of contacts	Description	Part number	PU (Tray)
110	without shielding	244-11000-15	35/140
110	with shielding (cPCI J1/J4)	244-11300-15	
90	with shielding (cPCI Telephony Spec)	244-11305-15	
–	Lower shield	244-11600-1	24/600

On request

- other contact surface
- also in THTR

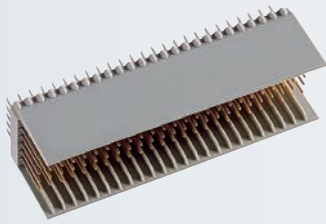

Type: Male connector straight with 5 rows

Termination: Press-fit

Number of contacts: 125, 175

Pitch: 2 mm

Operational current: 1.5 A

Packaging: Tube

Standard: IEC 61076-4-101



Technical Specifications on page 12

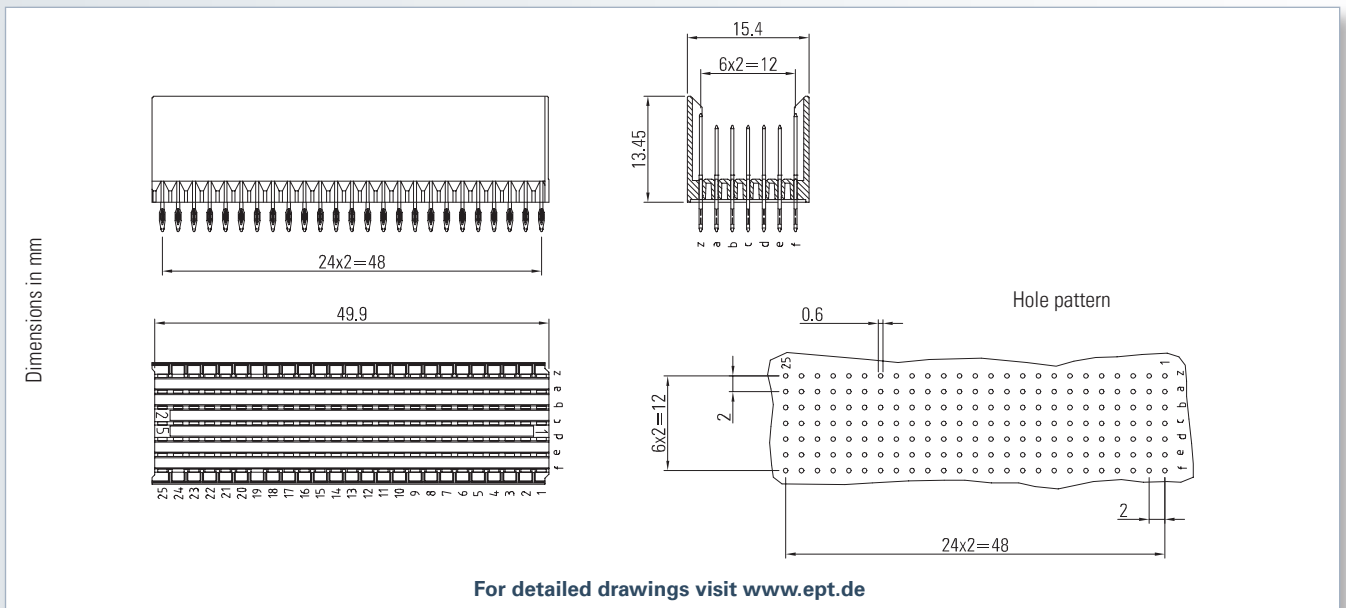

Accessories

- Shroud p. 74

Note

- Pin length p. 17

Mating connector / Application:



Type B25 Female connector (p. 24)



Einpresstechnik - Gütestufe II

No. of contacts	Contact arrangement	PCB thickness > 2.2 mm	
		Part number	PU (Tube)
125	<p>Diagram showing 125 contacts arranged in a 5x25 grid. All contacts are labeled 'A'. The grid is labeled with columns 25 to 1 and rows z to f.</p>	243-21010-15	10/240
125	<p>Diagram showing 125 contacts arranged in a 5x25 grid. All contacts are labeled 'B'. The grid is labeled with columns 25 to 1 and rows z to f.</p>	243-21020-15	
175	<p>Diagram showing 175 contacts arranged in a 5x35 grid. The first 25 columns are labeled 'A' and the last 5 columns are labeled 'C'. The grid is labeled with columns 25 to 1 and rows z to f.</p>	243-21310-15	
175	<p>Diagram showing 175 contacts arranged in a 5x35 grid. The first 25 columns are labeled 'B' and the last 5 columns are labeled 'C'. The grid is labeled with columns 25 to 1 and rows z to f.</p>	243-21320-15	

On request

- contact arrangement
- other contact surface

Ordering note

- PCB thickness 1.4 - 2.2 mm (Part number 243-21xxx-05)



Type B25 Female Connector



Type: Female connector 90° with 5 rows

Termination: Press-fit

Number of contacts: 125

Pitch: 2 mm

Operational current: 1.5 A

Packaging: Tray

Standard: IEC 61076-4-101



Technical Specifications on page 12

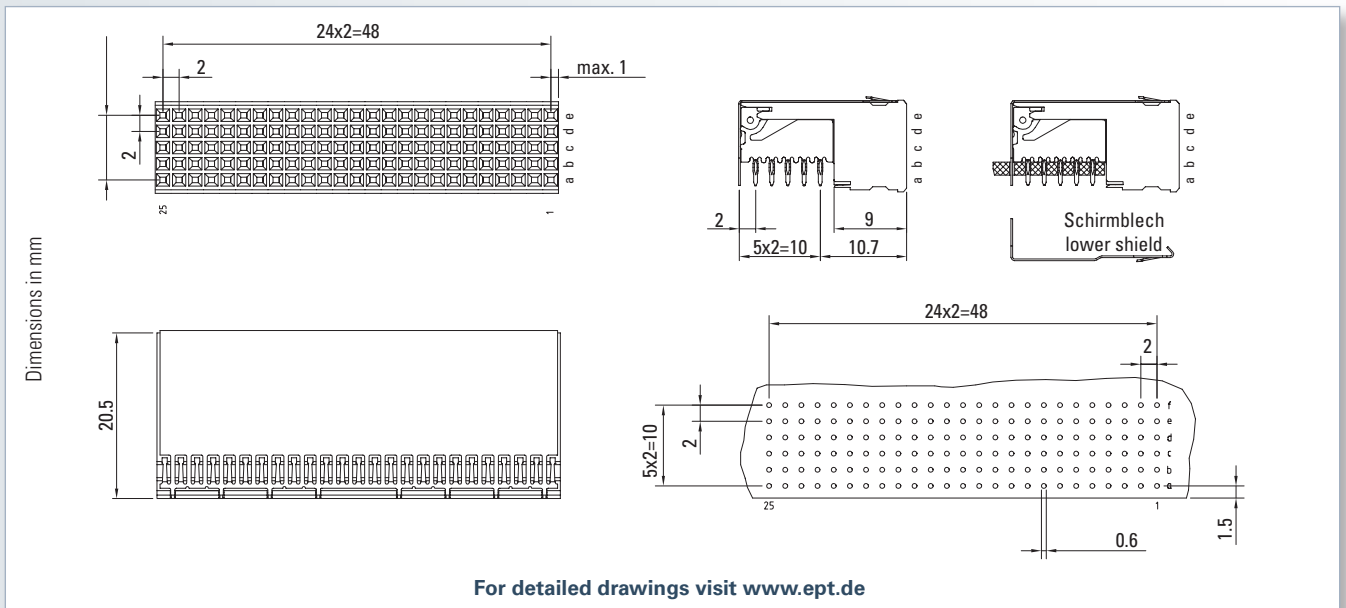

Mating connector / Application:



Type B25 Male connector (p. 22)



Press-fit - Performance level II •••

No. of contacts	Description	Part number	PU (Tray)
125	without shielding	244-21000-15	35/140
125	with shielding	244-21300-15	
–	Lower shield	244-21600-1	24/600

On request

- other contact surface
- also in THTR

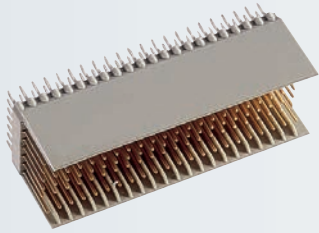

Type: Male connector straight with 5 rows

Termination: Press-fit

Number of contacts: 132, 154

Pitch: 2 mm

Operational current: 1.5 A

Packaging: Tube

Standard: IEC 61076-4-101



Technical Specifications on page 12

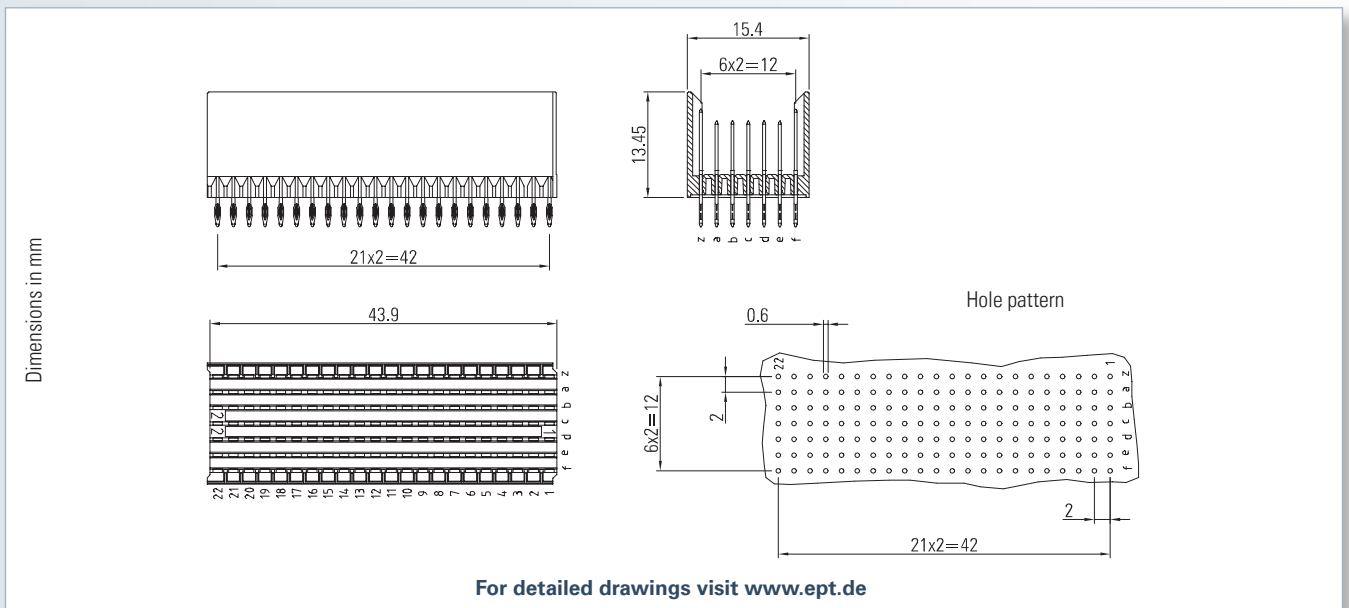

Accessories

- Shroud p. 74

Note

- Pin lengths p. 17
- CompactPCI P2/P5

Mating connector / Application:



Type B22 Female connector (p. 28)



Press-fit - Performance level II

No. of contacts	Contact arrangement	PCB thickness > 2.2 mm	
		Part number	PU (Tube)
154		243-22310-15	11/264
154		243-22311-15 cPCI Telephony Spec (P5)	
154		243-22320-15 cPCI (P2/P5)	
154		243-22360-15F cPCI (P2/P5)	

On request

- contact arrangement
- other contact surface

Ordering note

- PCB thickness 1.4 - 2.2 mm
(Part number 243-22xxx-05)

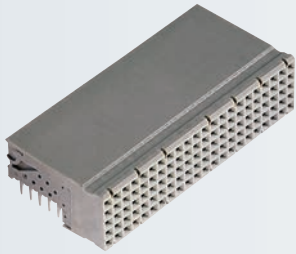

Type: Female connector 90° with 5 rows

Termination: Press-fit

Number of contacts: 110

Pitch: 2 mm

Operational current: 1.5 A

Packaging: Tray

Standard: IEC 61076-4-101



Technical Specifications on page 12

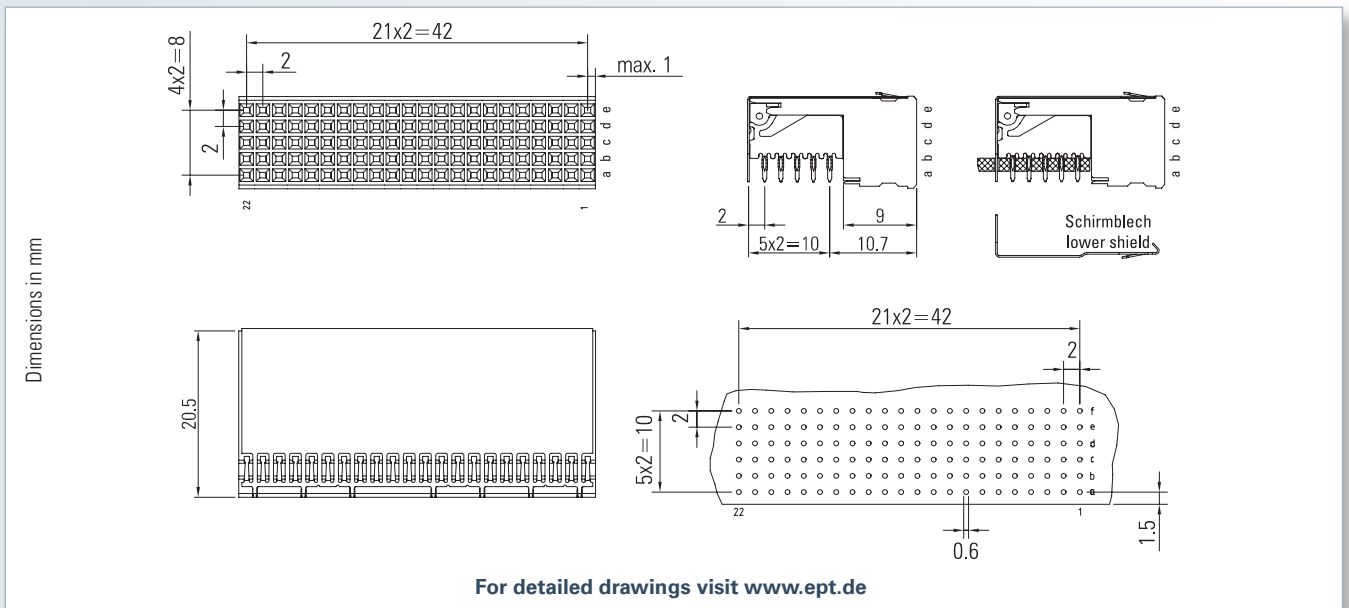

Note

- CompactPCI J2/J5

Mating connector / Application:



Type B22 Male connector (p. 26)



Press-fit - Performance level II •••

No. of contacts	Description	Part number	PU (Tray)
110	without shielding	244-22000-15	35/140
110	with shielding	244-22300-15	
–	Lower shield	244-22600-1	24/600

On request

- other contact surface
- also in THTR

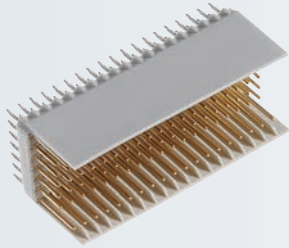

Type: Male connector straight with 5 rows

Termination: Press-fit

Number of contacts: 95, 133

Pitch: 2 mm

Operational current: 1.5 A

Packaging: Tube

Standard: IEC 61076-4-101



Technical Specifications on page 12

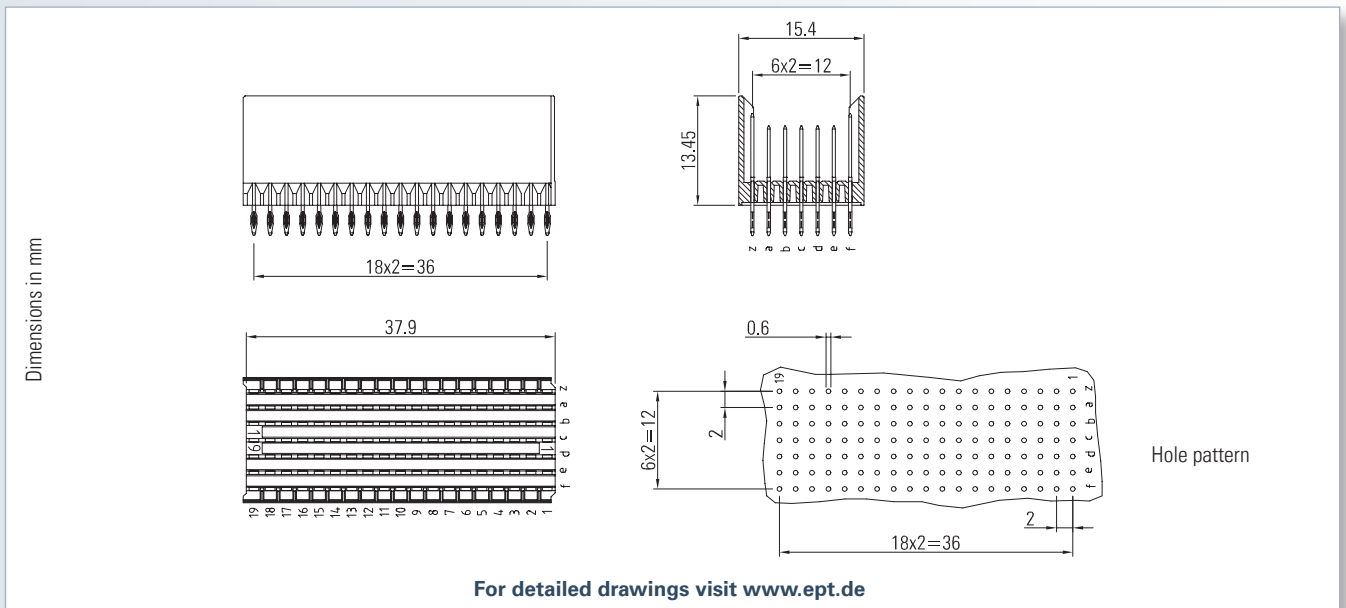

Accessories

- Shroud p. 74

Note

- Pin lengths p. 17
- VME J0 and cPCI P3

Mating connector / Application:



Type B19 Female connector (p. 32)



Press-fit - Performance level II

No. of contacts	Contact arrangement	PCB thickness > 2.2 mm	
		Part number	PU (Tube)
133		243-23310-15	13/312
133		243-23320-15	
133		243-23360-15F	
133		243-23700-15F	

On request

- contact arrangement
- other contact surface

Ordering note

- PCB thickness 1.4 - 2.2 mm (Part number 243-23xxx-05)

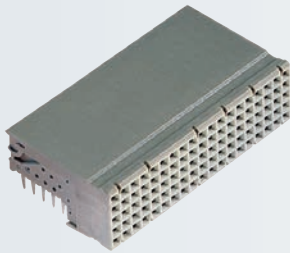

Type: Female connector 90° with 5 rows

Termination: Press-fit

Number of contacts: 95

Pitch: 2 mm

Operational current: 1.5 A

Packaging: Tray

Standard: IEC 61076-4-101



Technical Specifications on page 12

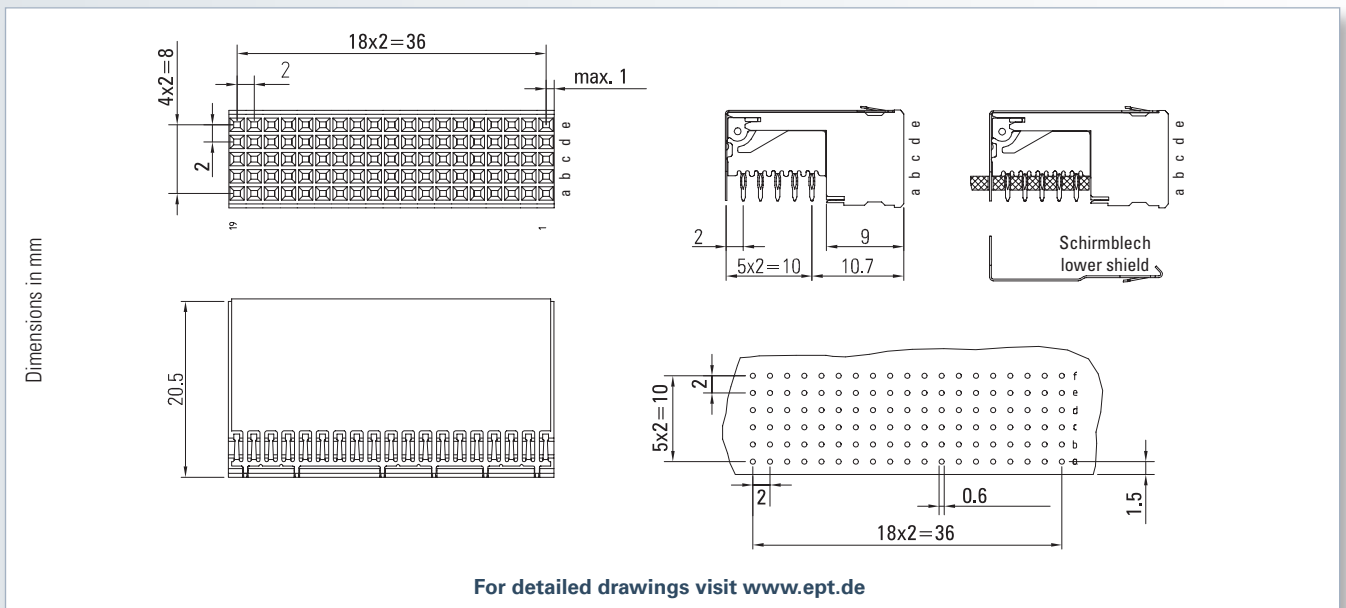

Note

- VME P0 and cPCI J3

Mating connector / Application:



Type B19 Male connector (p. 30)



Press-fit - Performance level II •••

No. of contacts	Description	Part number	PU (Tray)
95	without shielding	244-23000-15	42/168
95	with shielding	244-23300-15	
–	lower shield	244-23600-1	24/600

On request

- other contact surface
- also in THTR

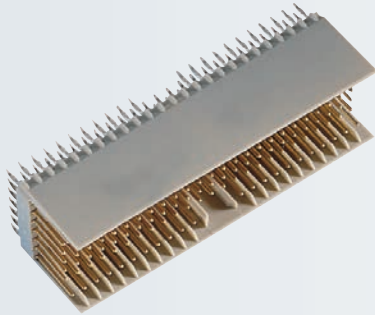

Type: Male connector straight with 5 rows

Termination: Press-fit

Number of contacts: 125, 169

Pitch: 2 mm

Operational current: 1.5 A

Packaging: Tube

Standard: IEC 61076-4-101



Technical Specifications on page 12

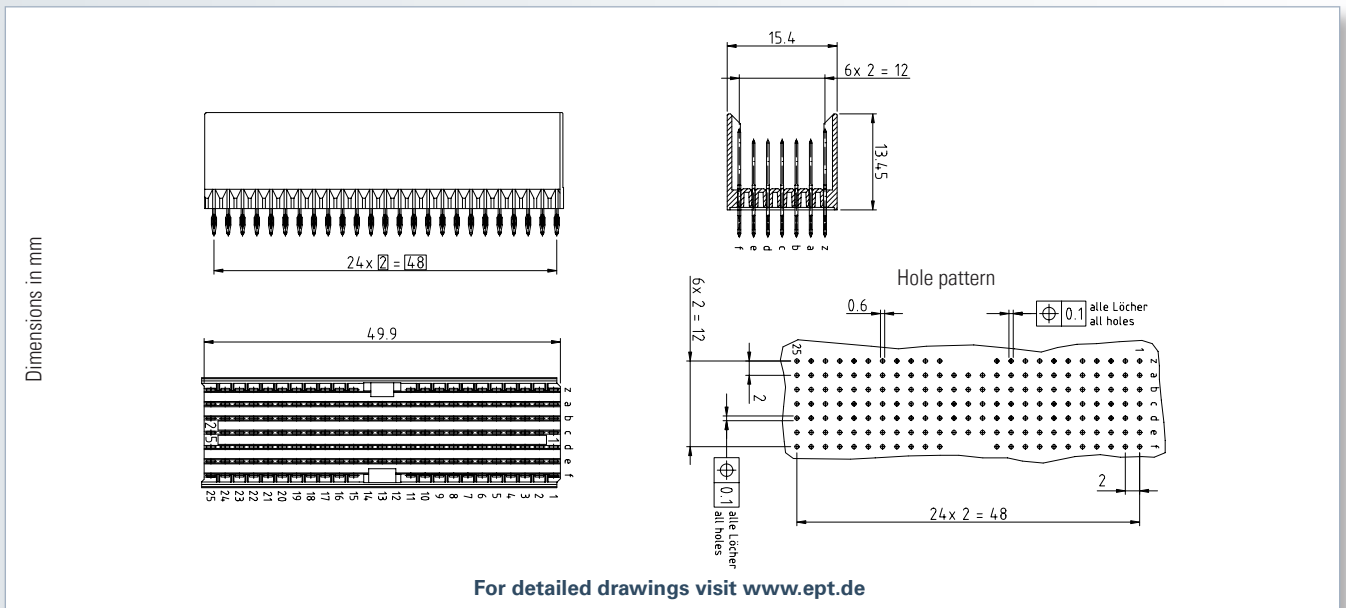

Accessories

- Shroud p. 74

Note

- Pin lengths p. 17

Mating connector / Application:



Type AB25 Female connector (p. 36)



Press-fit - Performance level II

No. of contacts	Contact arrangement	PCB thickness > 2.2 mm	
		Part number	PU (Tube)
125		243-61010-15	10/240
169		243-61310-15	
169		243-61320-15	
169		243-61360-15F	

On request

- contact arrangement
- other contact surface

Ordering note

- PCB thickness 1.4 - 2.2 mm (Part number 243-61xxx-05)

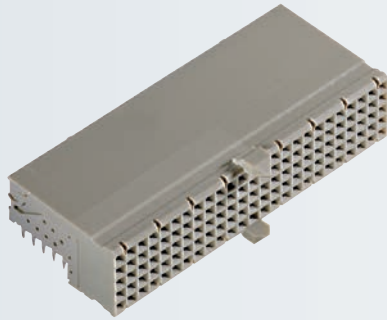

Type: Female connector 90° with 5 rows

Termination: Press-fit

Number of contacts: 125

Pitch: 2 mm

Operational current: 1.5 A

Packaging: Tray

Standard: IEC 61076-4-101



Technical Specifications on page 12

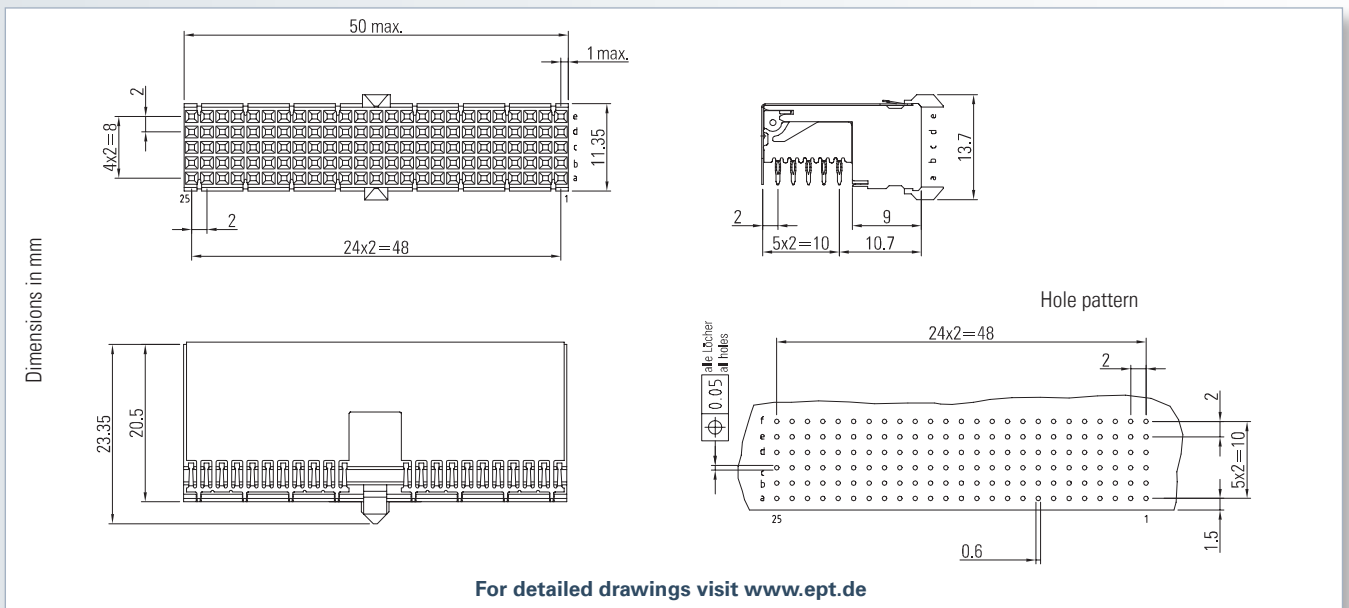

Mating connector / Application:



Type AB25 Male connector (p. 34)



Press-fit - Performance level II

No. of contacts	Description	Part number	PU (Tray)
125	without shielding	244-61000-15	35/140
125	with shielding	244-61300-15	
–	lower shield	244-11600-1	24/600

On request

- other contact surface
- also in THTR

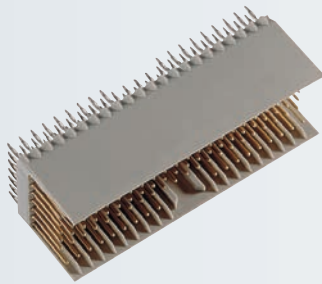

Type: Male connector straight with 5 rows

Termination: Press-fit

Number of contacts: 110, 146

Pitch: 2 mm

Operational current: 1.5 A

Packaging: Tube

Standard: IEC 61076-4-101



Technical Specifications on page 12

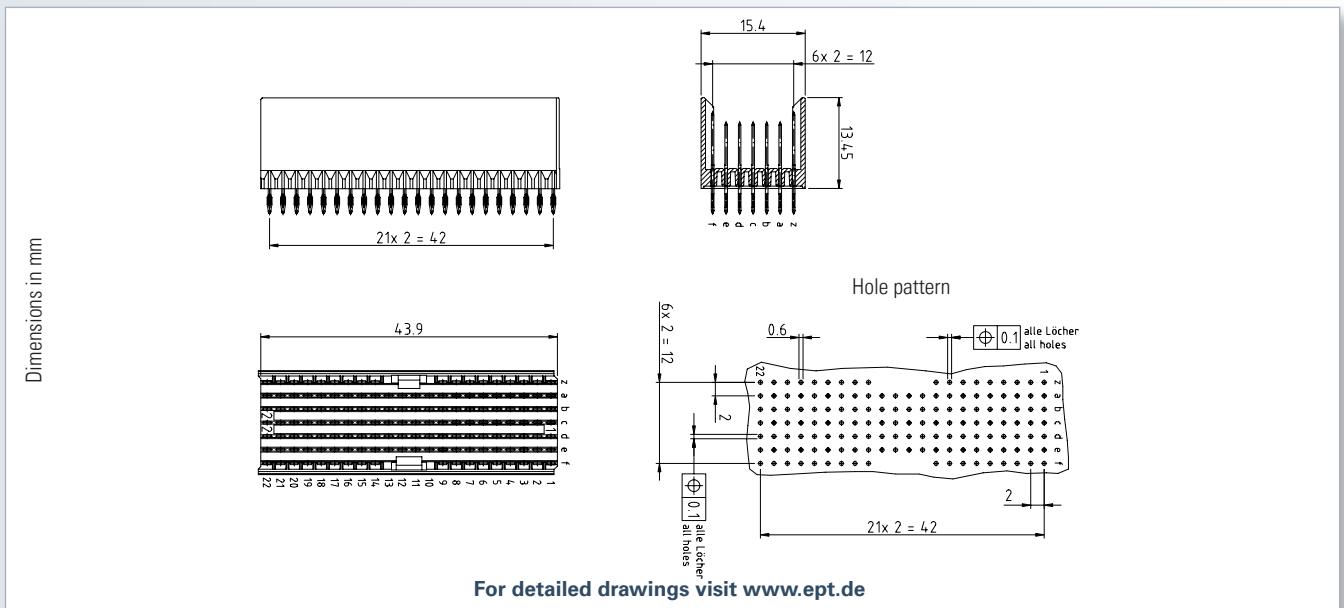

Accessories

- Shroud p. 74

Note

- Pin lengths p. 17

Mating connector / Application:



Type AB22 Female connector (p. 40)



Press-fit - Performance level II

No. of contacts	Contact arrangement	PCB thickness > 2.2 mm	
		Part number	PU (Tube)
110		243-62010-15	11/264
146		243-62310-15	
146		243-62320-15	
146		243-62360-15F	

On request

- contact arrangement
- other contact surface

Ordering note

- PCB thickness 1.4 - 2.2 mm (Part number 243-62xxx-05)

Type AB22 Female Connector

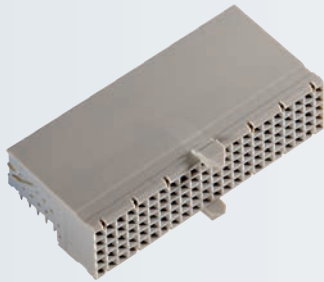

Type: Female connector 90° with 5 rows

Termination: Press-fit

Number of contacts: 110

Pitch: 2 mm

Operational current: 1.5 A

Packaging: Tray

Standard: IEC 61076-4-101



Technical Specifications on page 12

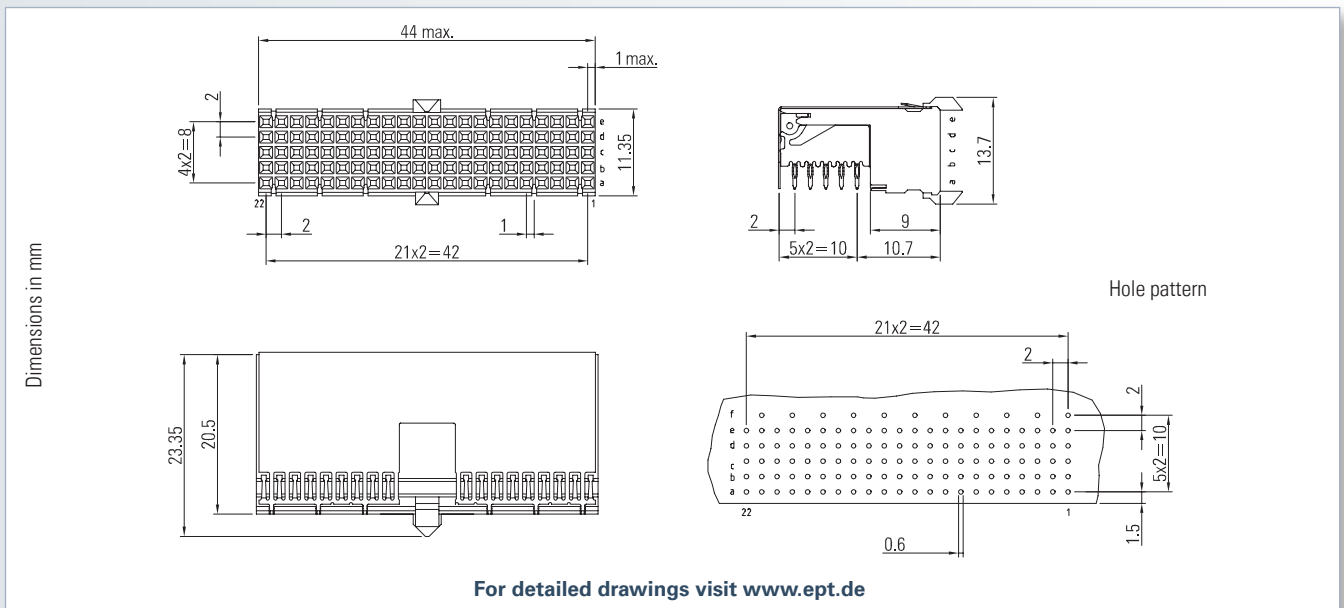

Note

- CompactPCI RJ5

Mating connector / Application:



Type AB22 Male connector (p. 38)



Press-fit - Performance level II

No. of contacts	Description	Part number	PU (Tray)
110	without shielding	244-62000-15	35/140
110	with shielding	244-62300-15	

On request

- other contact surface
- also in THTR

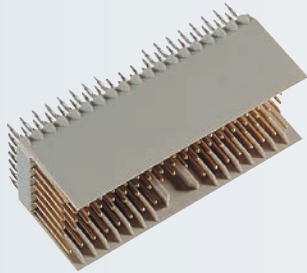

Type: Male connector straight with 5 rows

Termination: Press-fit

Number of contacts: 95, 127

Pitch: 2 mm

Operational current: 1.5 A

Packaging: Tube

Standard: IEC 61076-4-101



Technical Specifications on page 12

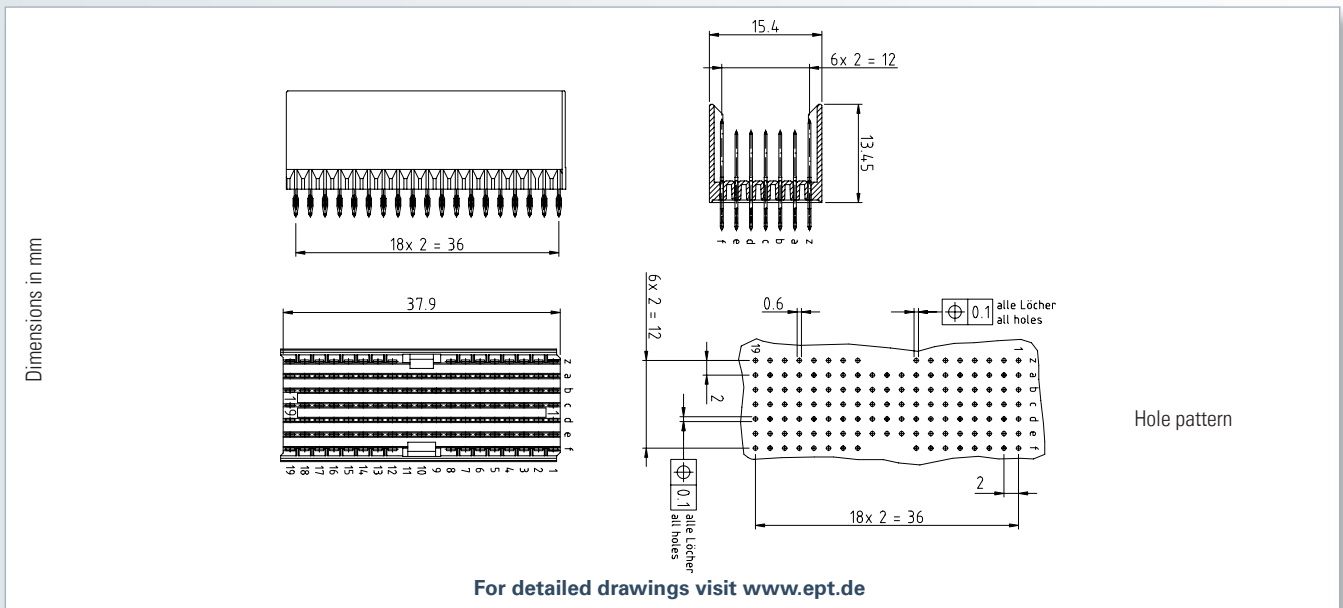

Accessories

- Shroud p. 74

Note

- Pin lengths p. 17

Mating connector / Application:



Type AB19 Female connector (p. 44)



Press-fit - Performance level II

No. of contacts	Contact arrangement	PCB thickness > 2.2 mm	
		Part number	PU (Tube)
95		243-63010-15	13/312
127		243-63310-15	
127		243-63320-15	
127		243-63360-15F	

On request

- other contact surface
- also in THTR

Ordering note

- PCB thickness 1.4 - 2.2 mm (Part number 243-63xxx-05)

Type AB19 Female Connector

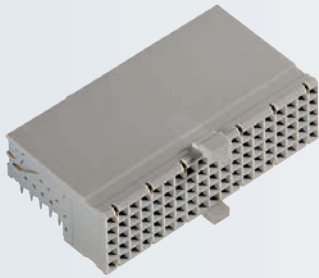

Type: Female connector 90° with 5 rows

Termination: Press-fit

Number of contacts: 95

Pitch: 2 mm

Operational current: 1.5 A

Packaging: Tray

Standard: IEC 61076-4-101



Technical Specifications on page 12

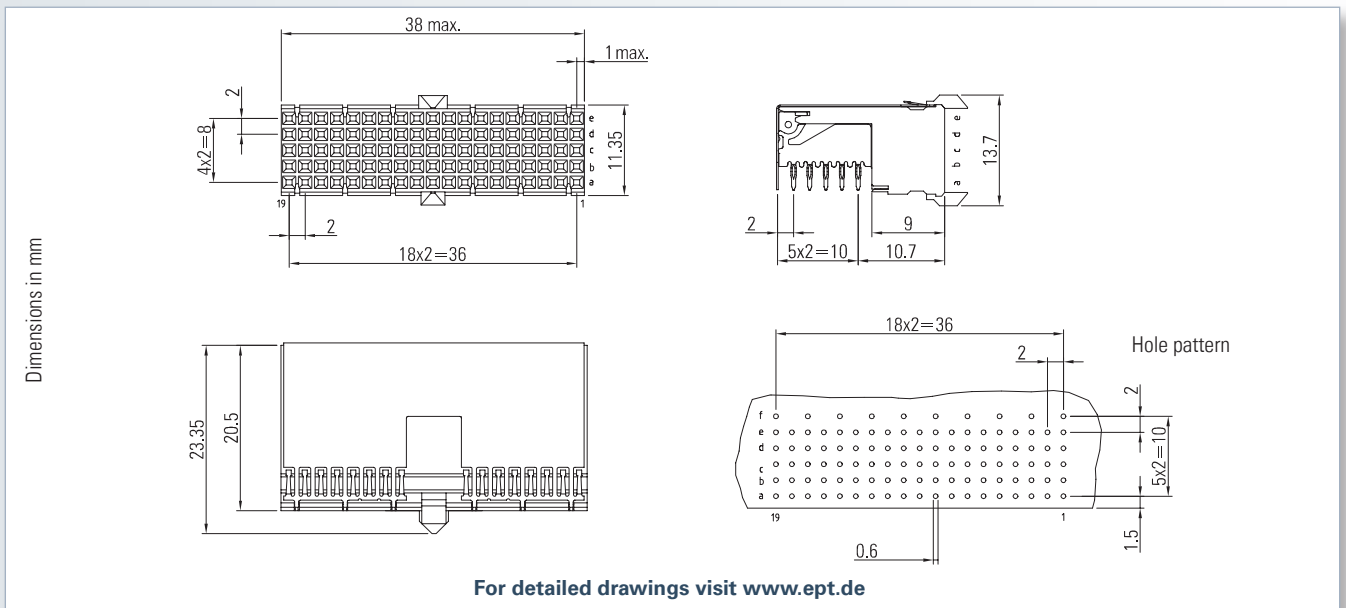

Note

- CompactPCI RJ3

Mating connector / Application:

Type AB19 Male connector (p. 42)



Press-fit - Performance level II •••

No. of contacts	Description	Part number	PU (Tray)
95	without shielding	244-63000-15	35/140
95	with shielding	244-63300-15	

On request

- other contact surface
- also in THTR

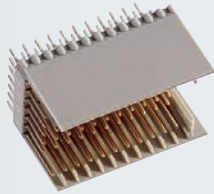

Type: Male connector straight with 5 rows

Termination: Press-fit

Number of contacts: 55, 77

Pitch: 2 mm

Operational current: 1.5 A

Packaging: Tube

Standard: IEC 61076-4-101



Technical Specifications on page 12

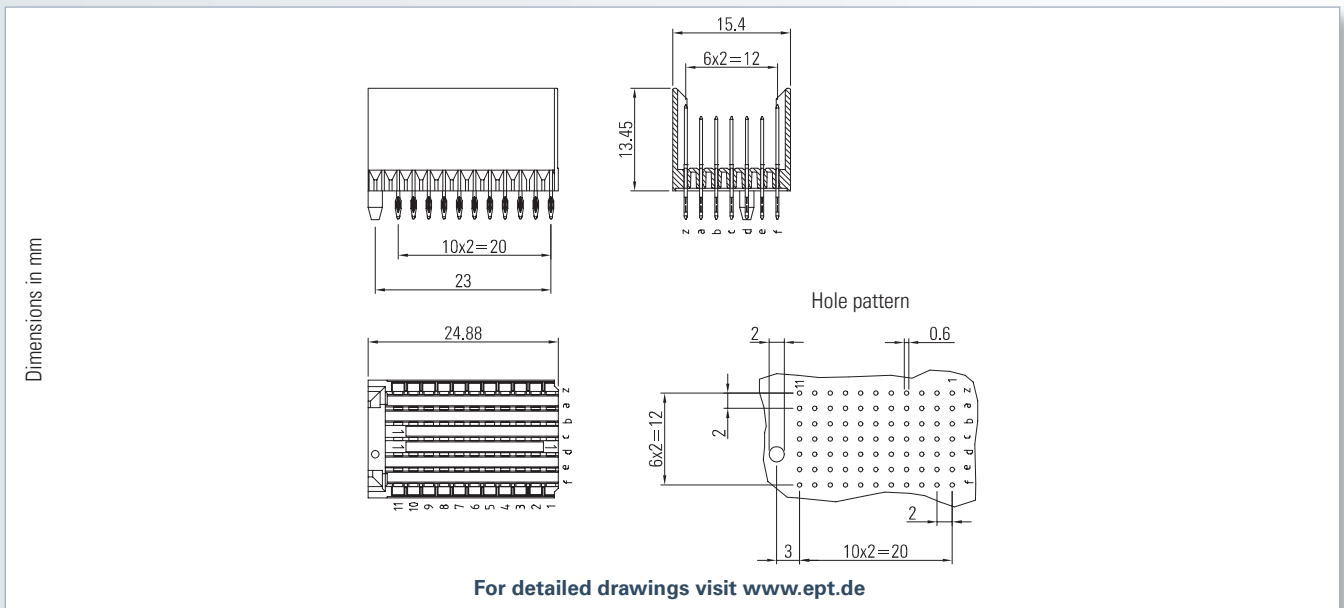

Accessories

- Shroud p. 74

Note

- Pin lengths p. 17

Mating connector / Application:



Type C Female connector (p. 48)



Press-fit - Performance level II ● ● ●

No. of contacts	Contact arrangement	PCB thickness > 2.2 mm	
		Part number	PU (Tube)
55		243-31010-15	20/480
55		243-31020-15	
77		243-31310-15	
77		243-31320-15	

On request

- contact arrangement
- other contact surface

Ordering note

- PCB thickness 1.4 - 2.2 mm
(Part number 243-31xxx-05)

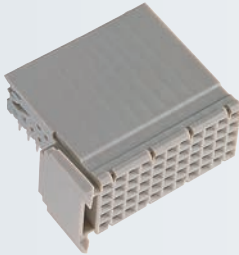

Type: Female connector 90° with 5 rows

Termination: Press-fit

Number of contacts: 55

Pitch: 2 mm

Operational current: 1.5 A

Packaging: Tray

Standard: IEC 61076-4-101



Technical Specifications on page 12

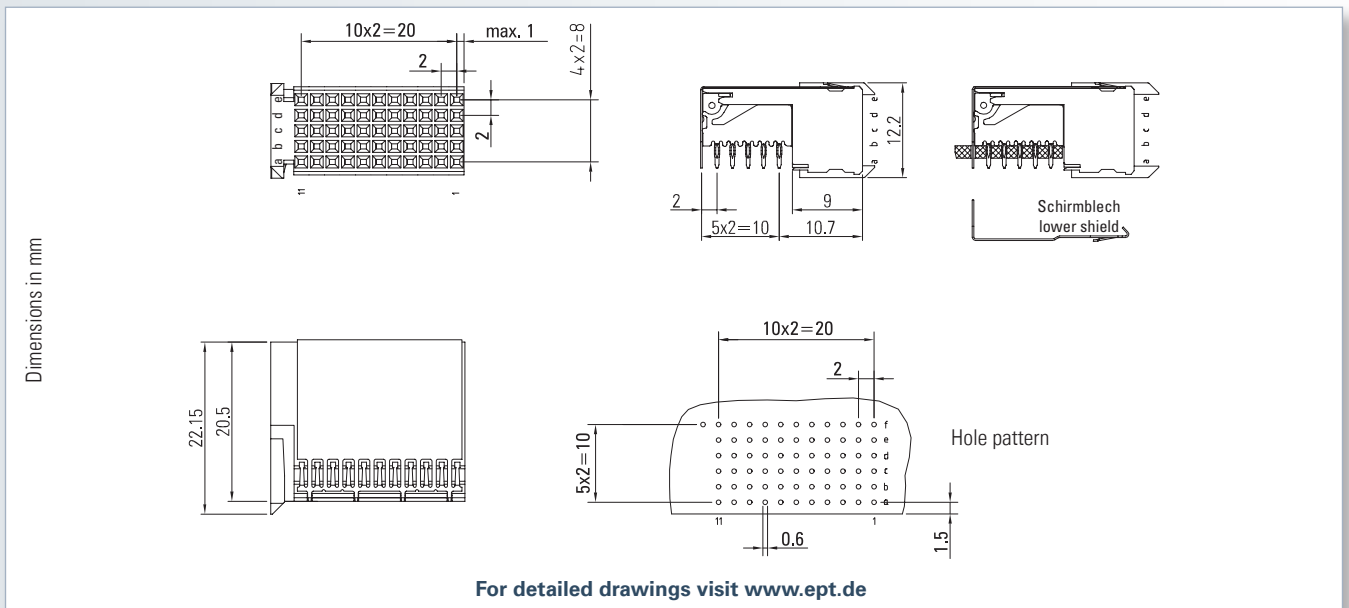

Mating connector / Application:

Type C Male connector (p. 46)



Press-fit - Performance level II

No. of contacts	Description	Part number	PU (Tray)
55	without shielding	244-31000-15	70/280
55	with shielding	244-31300-15	
–	lower shield	244-31600-1	48/600

On request

- other contact surface
- also in THTR

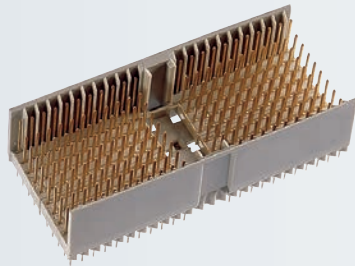

Type: Male connector straight with 8 rows

Termination: Press-fit

Number of contacts: 176, 220

Pitch: 2 mm

Operational current: 1.5 A

Packaging: Tube

Standard: IEC 61076-4-101



Technical Specifications on page 12

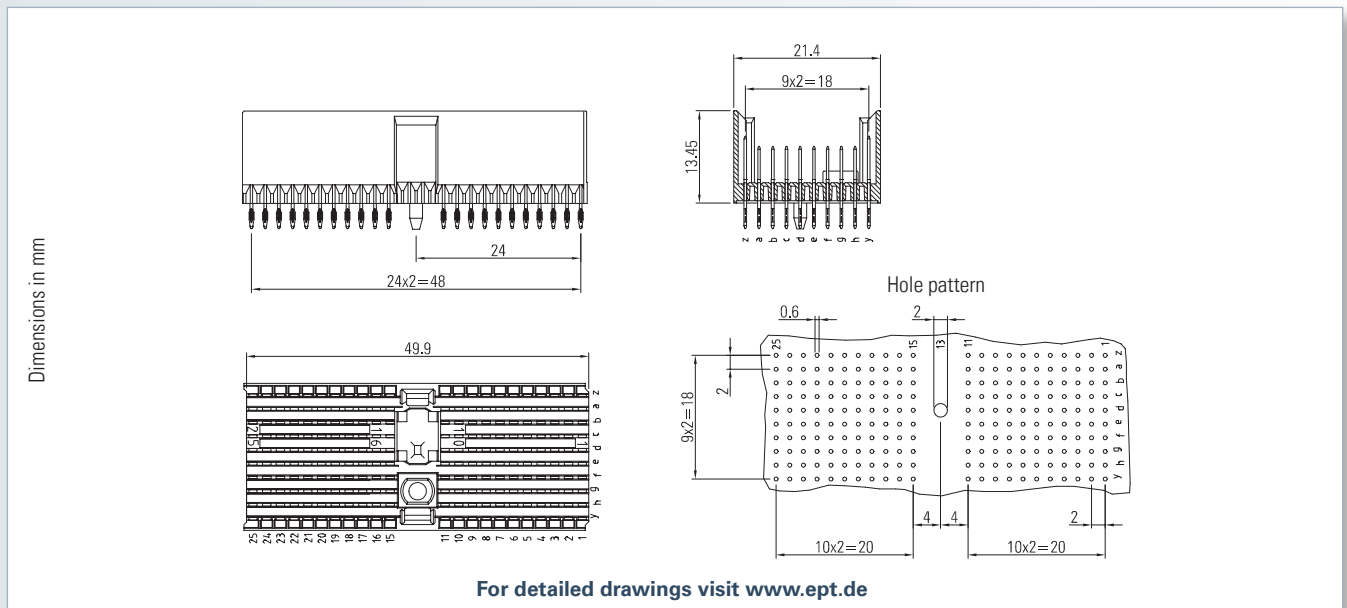

Accessories

- Coding p. 76

Note

- Pin lengths p. 17

Mating connector / Application:



Type D Female connector (p. 52)



Press-fit - Performance level II

No. of contacts	Contact arrangement	PCB thickness > 2.2 mm	
		Part number	PU (Tube)
176		245-11010-15	10/160
220		245-11310-15	

On request

- contact arrangement
- other contact surface

Ordering note

- PCB thickness 1.4 - 2.2 mm (Part number 245-11xxx-05)

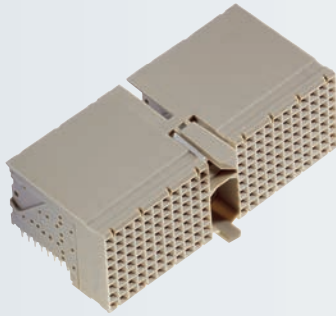

Type: Female connector 90° with 8 rows

Termination: Press-fit

Number of contacts: 176

Pitch: 2 mm

Operational current: 1.5 A

Packaging: Tray

Standard: IEC 61076-4-101



Technical Specifications on page 12

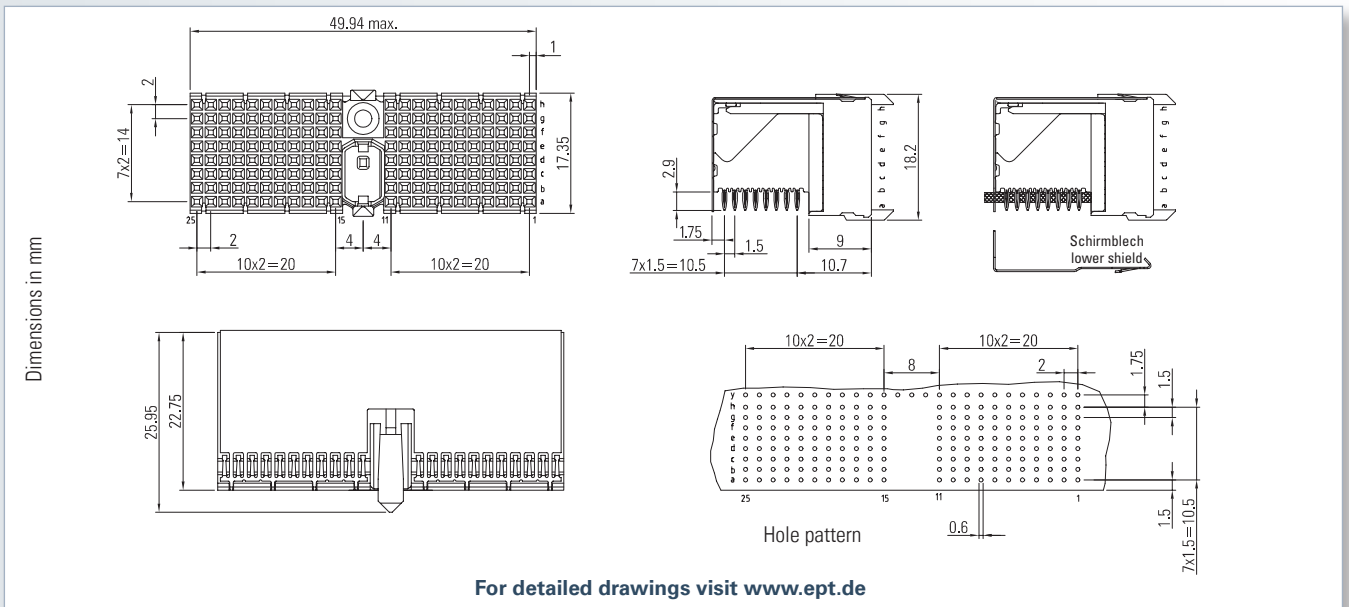

Accessories

- Coding p. 76

Mating connector / Application:



Type D Male connector (p. 50)



Press-fit - Performance level II

No. of contacts	Description	Part number	PU (Tray)
176	without shielding	246-11000-15	30/90
176	with shielding	246-11300-15	
–	lower shield	246-11600-1	24/600

On request
 • other contact surface

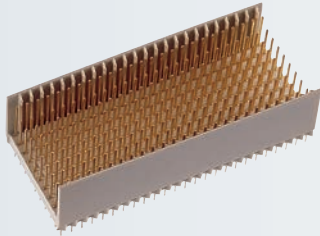

Type: Male connector straight with 8 rows

Termination: Press-fit

Number of contacts: 200, 250

Pitch: 2 mm

Operational current: 1.5 A

Packaging: Tube

Standard: IEC 61076-4-101



Technical Specifications on page 12

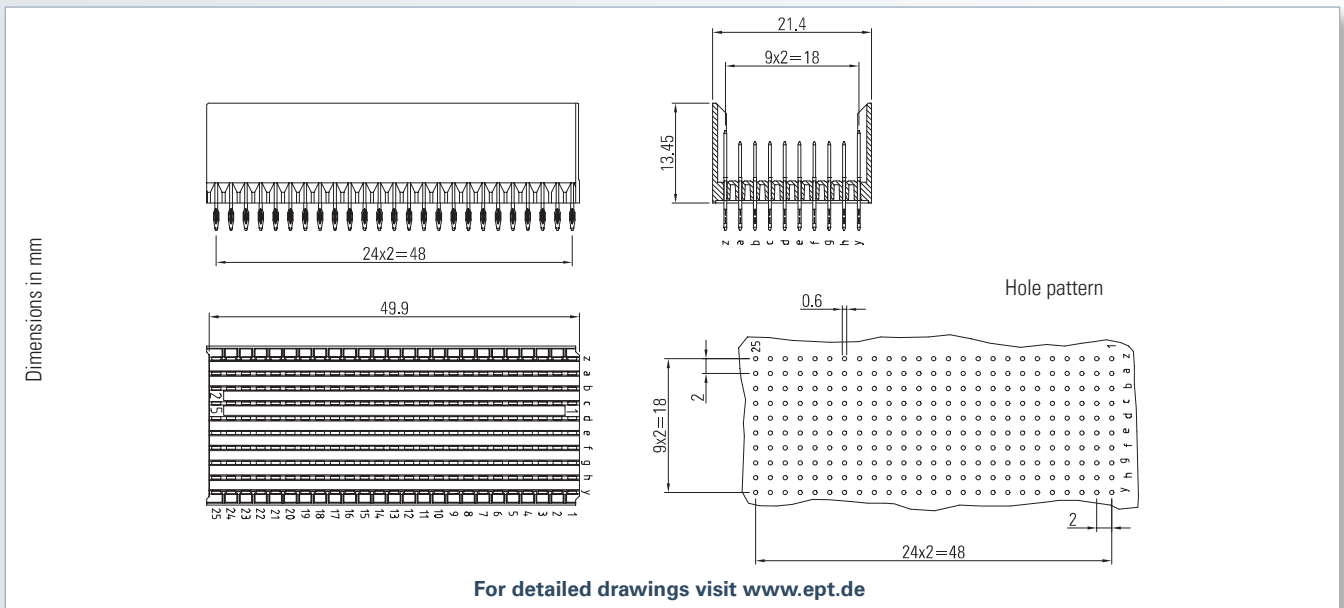

Note

- Pin lengths p. 17

Mating connector / Application:



Type E Female connector (p. 56)



Press-fit - Performance level II

No. of contacts	Contact arrangement	PCB thickness > 2.2 mm	
		Part number	PU (Tube)
200		245-21010-15	10/160
250		245-21310-15	

On request

- contact arrangement
- other contact surface

Ordering note

- PCB thickness 1.4 - 2.2 mm (Part number 245-21xxx-05)



Type: Female connector 90° with 8 rows

Termination: Press-fit

Number of contacts: 200

Pitch: 2 mm

Operational current: 1.5 A

Packaging: Tray

Standard: IEC 61076-4-101



Technical Specifications on page 12

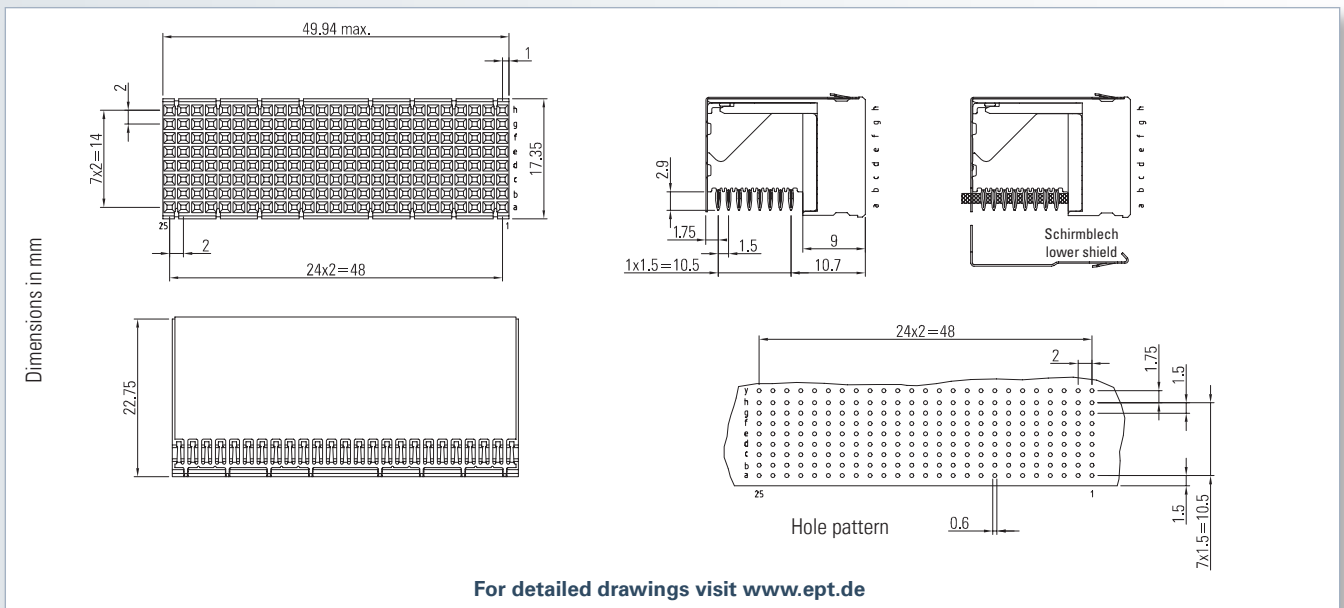

Mating connector / Application:



Type E Male connector (p. 54)



Press-fit - Performance level II •••

No. of contacts	Description	Part number	PU (Tray)
200	without shielding	246-21000-15	30/90
200	with shielding	246-21300-15	
–	lower shield	246-21600-1	24/600

On request
 • other contact surface

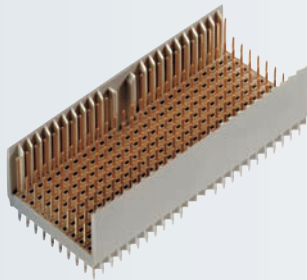

Type: Male connector straight with 8 rows

Termination: Press-fit

Number of contacts: 200, 244

Pitch: 2 mm

Operational current: 1.5 A

Packaging: Tube

Standard: IEC 61076-4-101



Technical Specifications on page 12

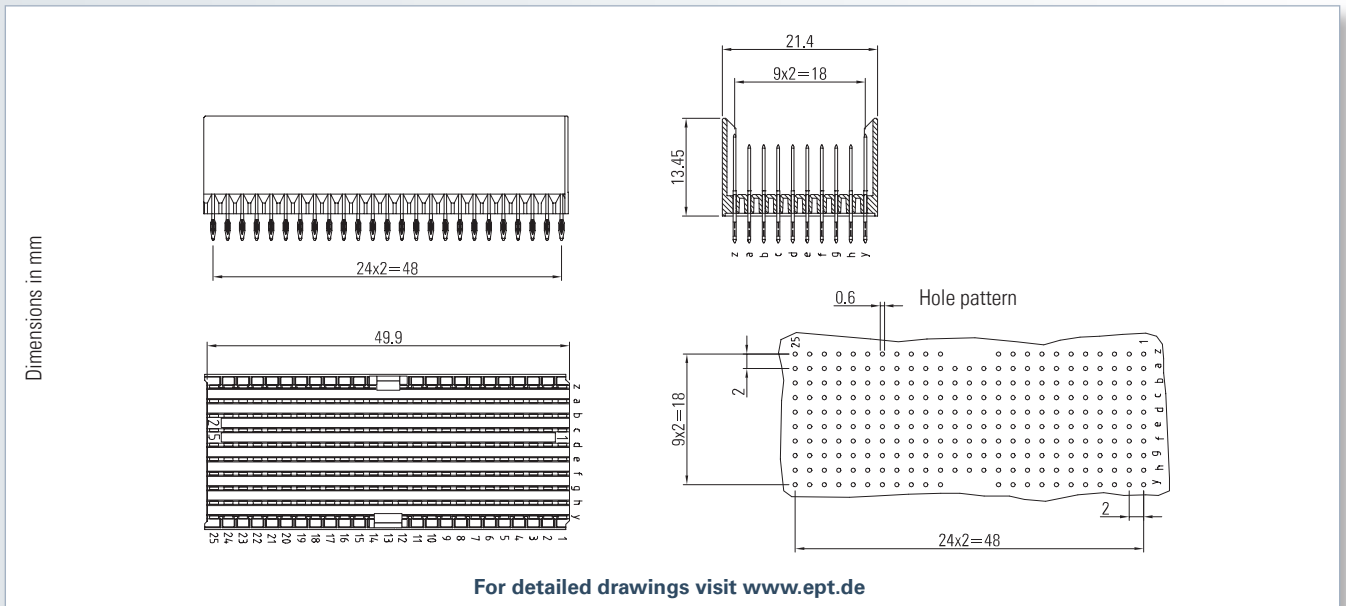

Note

- Pin lengths p. 17

Mating connector / Application:



Type DE Female connector (p. 60)



Press-fit - Performance level II

No. of contacts	Contact arrangement	PCB thickness > 2.2 mm	
		Part number	PU (Tube)
200		245-61010-15	10/160
244		245-61310-15	

On request

- contact arrangement
- other contact surface

Ordering note

- PCB thickness 1.4 - 2.2 mm (Part number 245-61xxx-05)

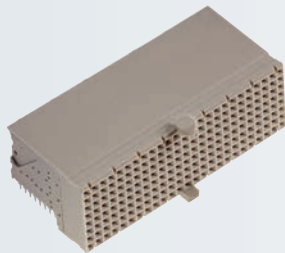

Type: Female connector 90° with 8 rows

Termination: Press-fit

Number of contacts: 200

Pitch: 2 mm

Operational current: 1.5 A

Packaging: Tray

Standard: IEC 61076-4-101



Technical Specifications on page 12

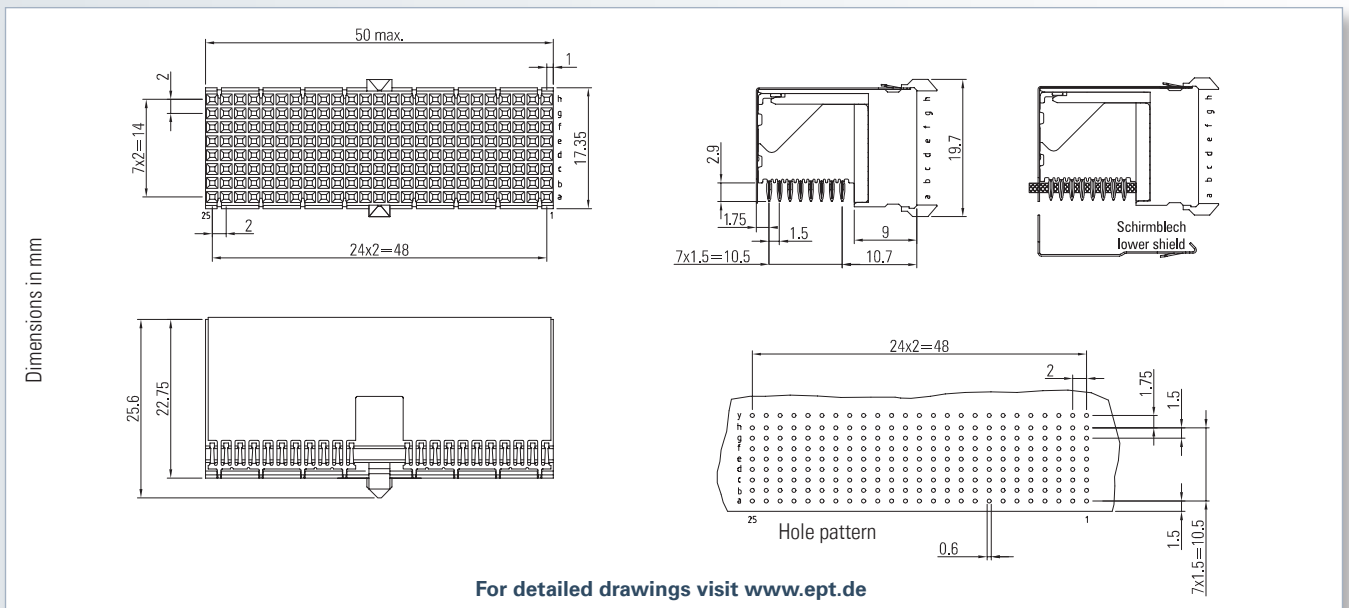

Mating connector / Application:



Type DE Male connector (p. 58)



Press-fit - Performance level II •••

No. of contacts	Description	Part number	PU (Tray)
200	without shielding	246-61000-15	30/90
200	with shielding	246-61300-15	
–	lower shield	246-11600-1	24/600

On request
 • other contact surface

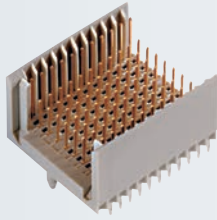

Type: Male connector straight with 8 rows

Termination: Press-fit

Number of contacts: 88, 110

Pitch: 2 mm

Operational current: 1.5 A

Packaging: Tube

Standard: IEC 61076-4-101



Technical Specifications on page 12

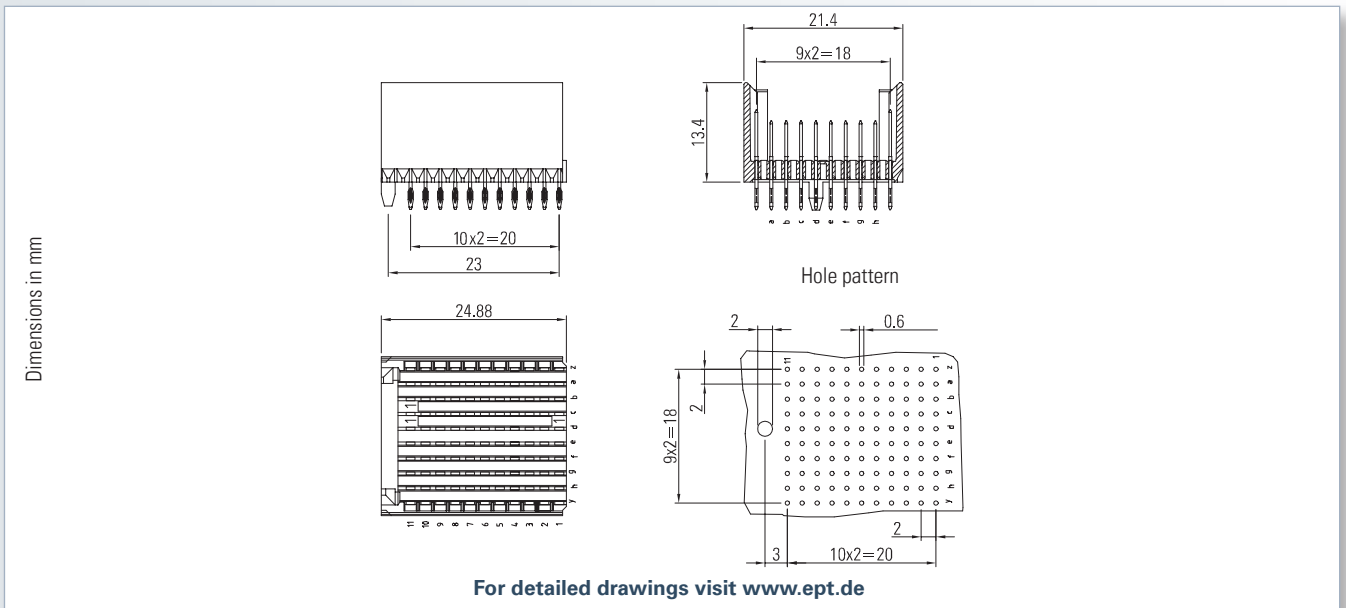

Note

- Pin lengths p. 17

Mating connector / Application:



Type F Female connector (p. 64)



Press-fit - Performance level II

No. of contacts	Contact arrangement	PCB thickness > 2.2 mm	
		Part number	PU (Tube)
88		245-31010-15	20/320
110		245-31310-15	

On request

- contact arrangement
- other contact surface

Ordering note

- PCB thickness 1.4 - 2.2 mm (Part number 245-31xxx-05)

hm2.0



Type F Female Connector

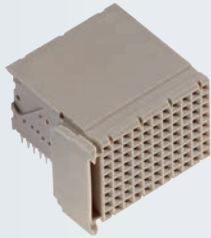

Type: Female connector 90° with 8 rows

Termination: Press-fit

Number of contacts: 88

Pitch: 2 mm

Operational current: 1.5 A

Packaging: Tray

Standard: IEC 61076-4-101



Technical Specifications on page 12

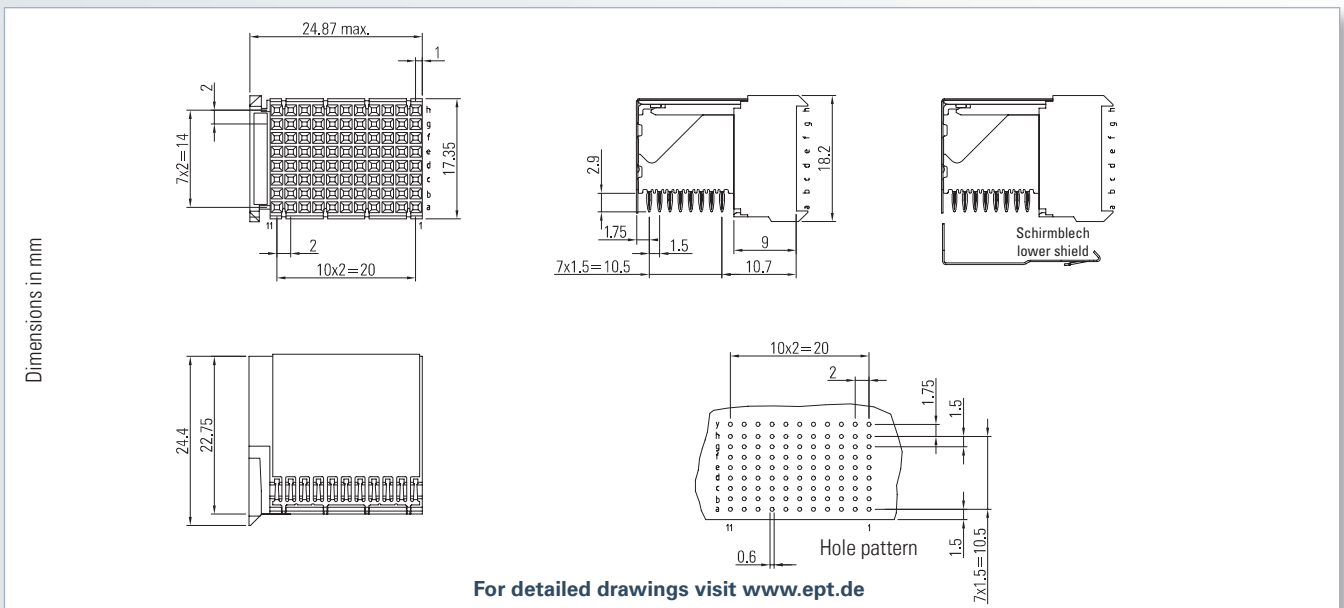

Mating connector / Application:



Type F Male connector (p. 62)



Press-fit - Performance level II •••

No. of contacts	Description	Part number	PU (Tray)
88	without shielding	246-31000-15	60/180
88	with shielding	246-31300-15	
–	lower shield	246-31600-1	24/600

On request
 • other contact surface

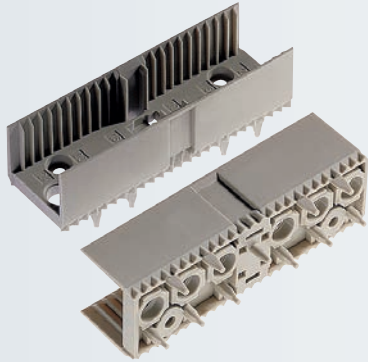

Type: Male connector straight
Termination: Press-fit
Number of contacts: 6
Pitch: 2 mm
Packaging: Bulk
Standard: IEC 61076-4-101



Technical Specifications on page 12

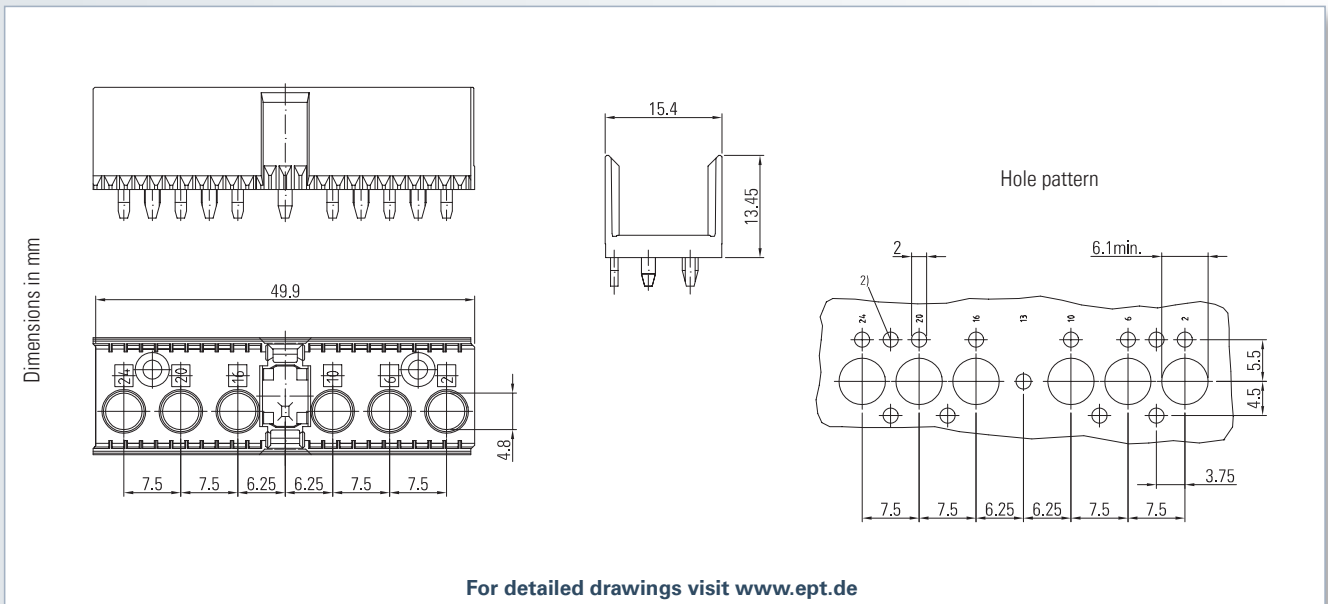

No. of contacts	Description	Part number	PU (Bulk)
6		243-51000	750

Mating connector / Application:



Type L Female connector (p. 67)

Type L Female Connector

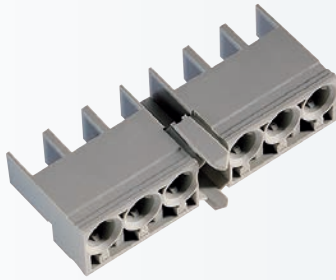

Type: Female connector 90°

Termination: Press-fit

Number of contacts: 6

Pitch: 2 mm

Packaging: Bulk

Standard: IEC 61076-4-101



Technical Specifications on page 12

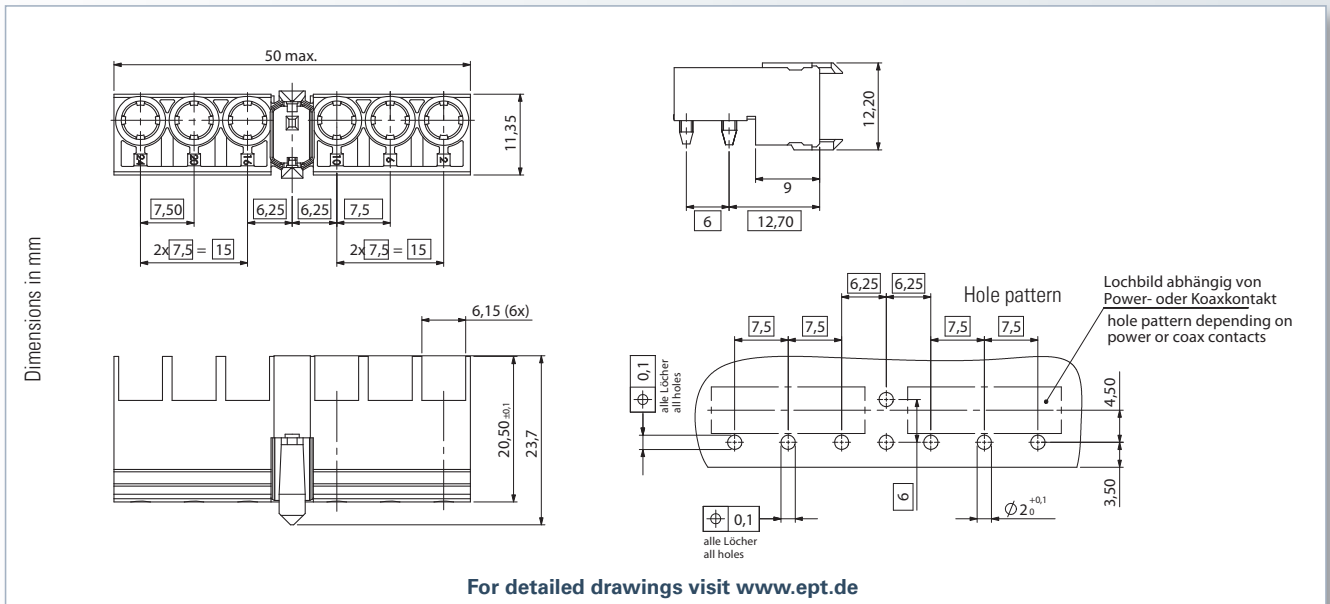

No. of contacts	Description	Part number	PU (Bulk)
6	without shielding	244-51000	140

Mating connector / Application:



Type L Male connector (p. 66)

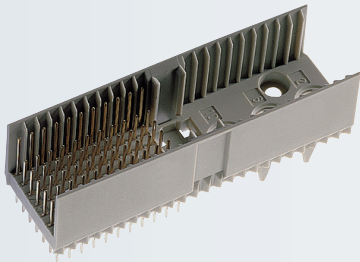

Type: Male connector straight with 5 rows

Termination: Press-fit

Number of contacts: 55, 77

Pitch: 2 mm

Operational current: 1.5 A

Packaging: Tube

Standard: IEC 61076-4-101



Technical Specifications on page 12

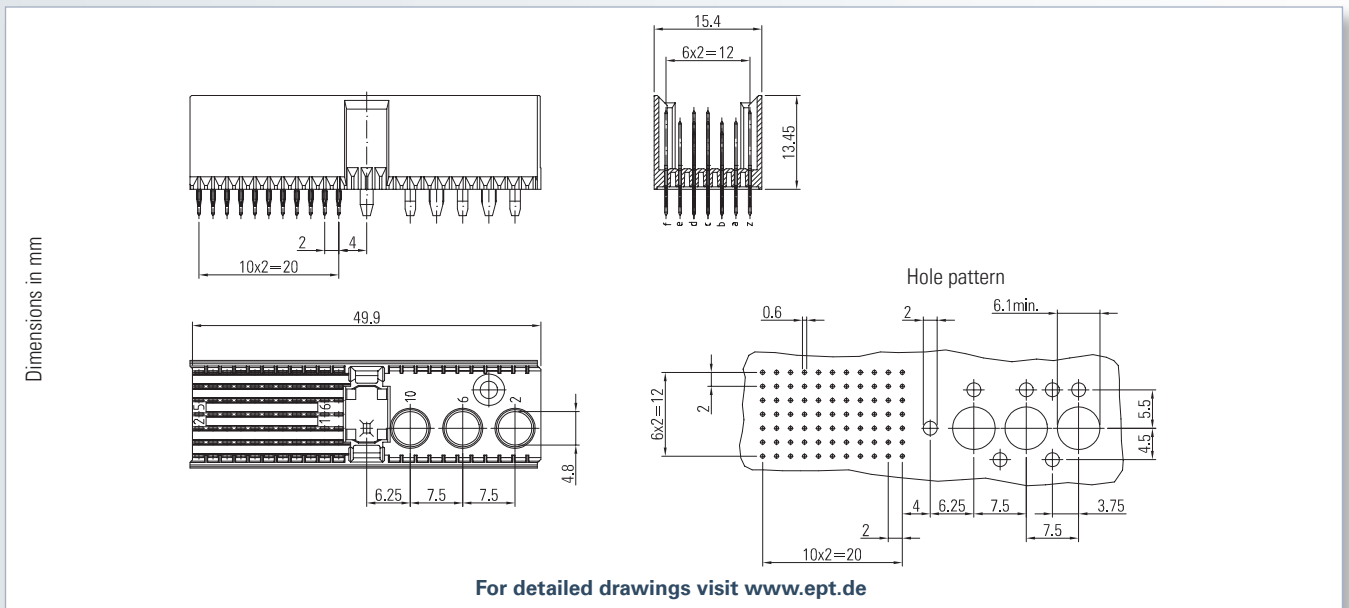

Accessories

- Coding p. 76

Note

- Pin length p. 17

Mating connector / Application:



Type M Female connector (p. 70)



Press-fit - Performance level II

No. of contacts	Contact arrangement	PCB thickness > 2.2 mm	
		Part number	PU (Tube)
55+3		243-41010-15	10/240
77+3		243-41310-15	

On request

- contact arrangement
- other contact surface
- processing tools

Ordering note

- PCB thickness 1.4 - 2.2 mm
(Part number 243-41xxx-05)

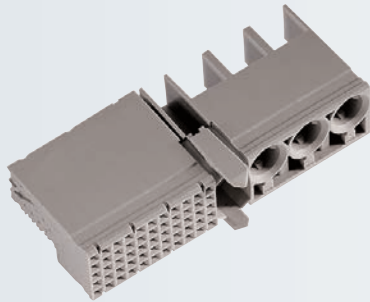

Type: Female connector 90° with 5 rows

Termination: Press-fit

Number of contacts: 55

Pitch: 2 mm

Operational current: 1.5 A

Packaging: Tray

Standard: IEC 61076-4-101



Technical Specifications on page 12

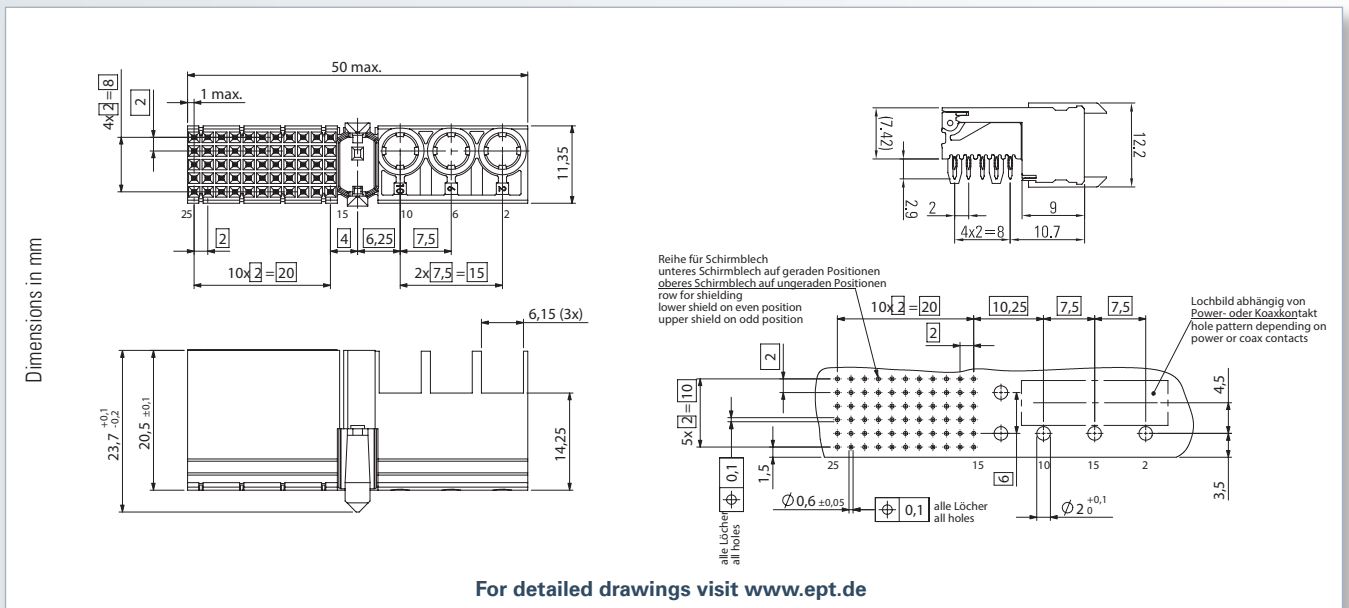

Accessories

- Coding p. 76

Mating connector / Application:



Type M Male connector (p. 68)



Press-fit - Performance level II •••

No. of contacts	Description	Part number	PU (Tray)
55+3	without shielding	244-41000-15	35/140
55+3	with shielding	244-41300-15	
–	lower shield	244-31600-1	48/1200

On request

- other contact surface
- processing tools

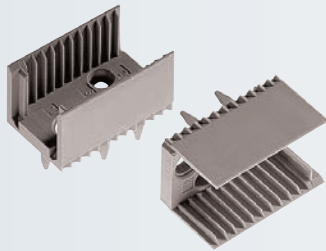

Type: Male connector straight

Termination: Press-fit

Number of contacts: 3

Pitch: 2 mm

Packaging: Bulk

Standard: IEC 61076-4-101



Technical Specifications on page 12

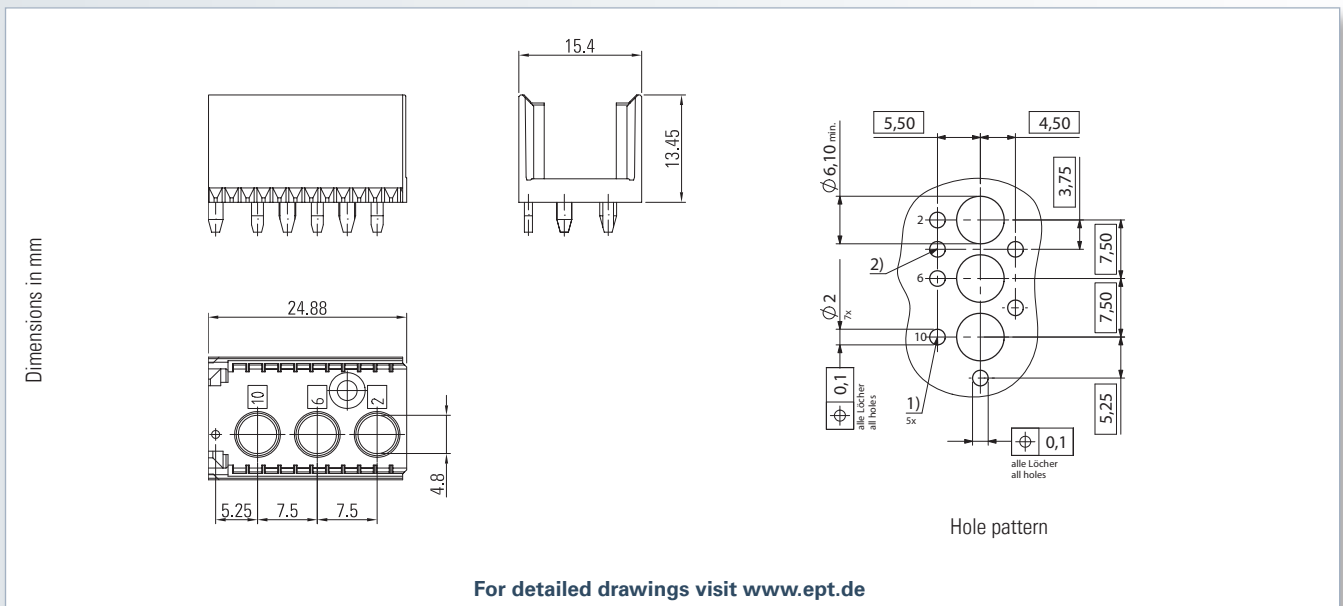

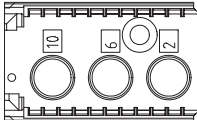
No. of contacts	Contact arrangement	Part number	PU (Bulk)
3	without shielding 	243-52000	1800

Mating connector / Application:



Type N Female connector (p. 73)

Type N Female Connector



Type: Female connector 90°

Termination: Press-fit

Number of contacts: 3

Pitch: 2 mm

Packaging: Bulk

Standard: IEC 61076-4-101



Technical Specifications on page 12

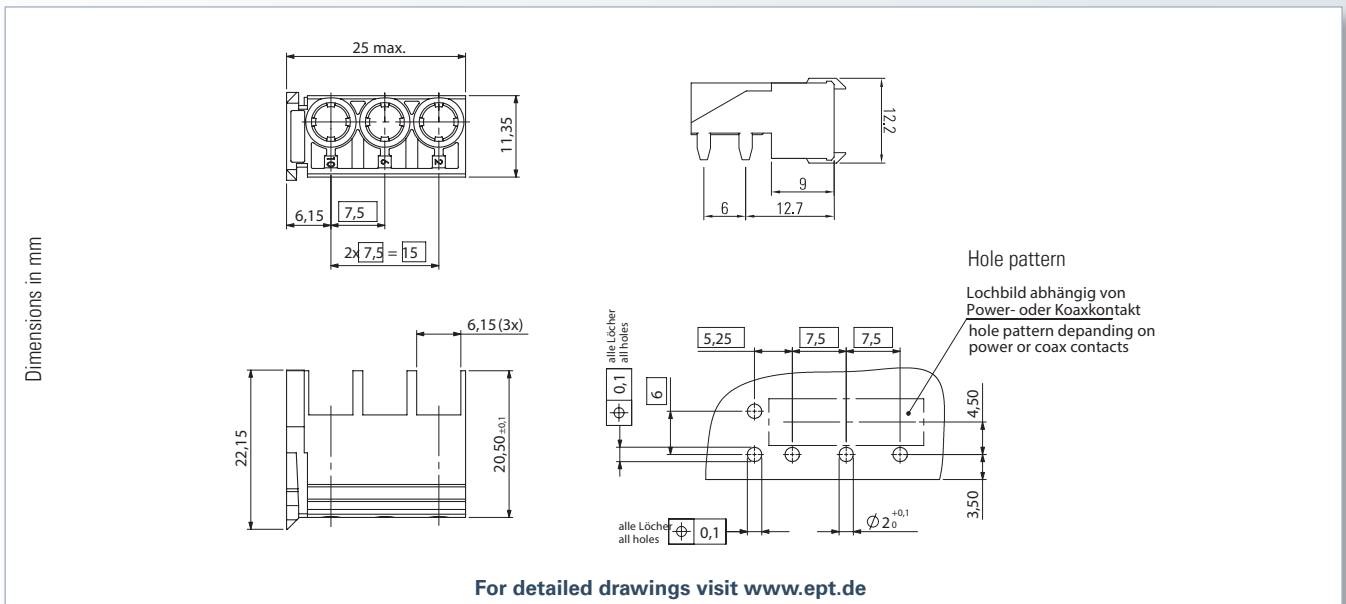

No. of contacts	Description	Part number	PU (Bulk)
3	ohne Abschirmung	244-52000	280

Mating connector / Application:



Type N Male connector (p. 72)

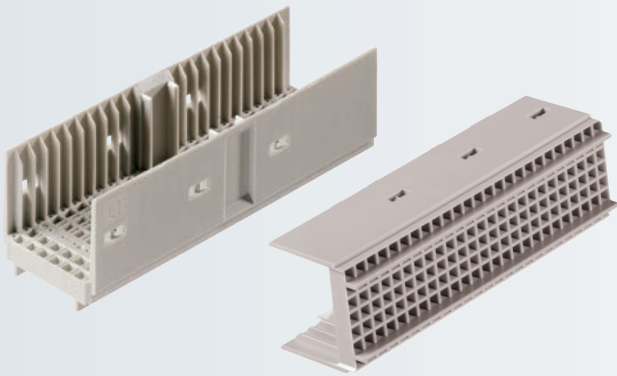

Type: Shroud

Pitch: 2 mm

Packaging: Bulk

Standard: IEC 61076-4-101



Technical Specifications on page 12

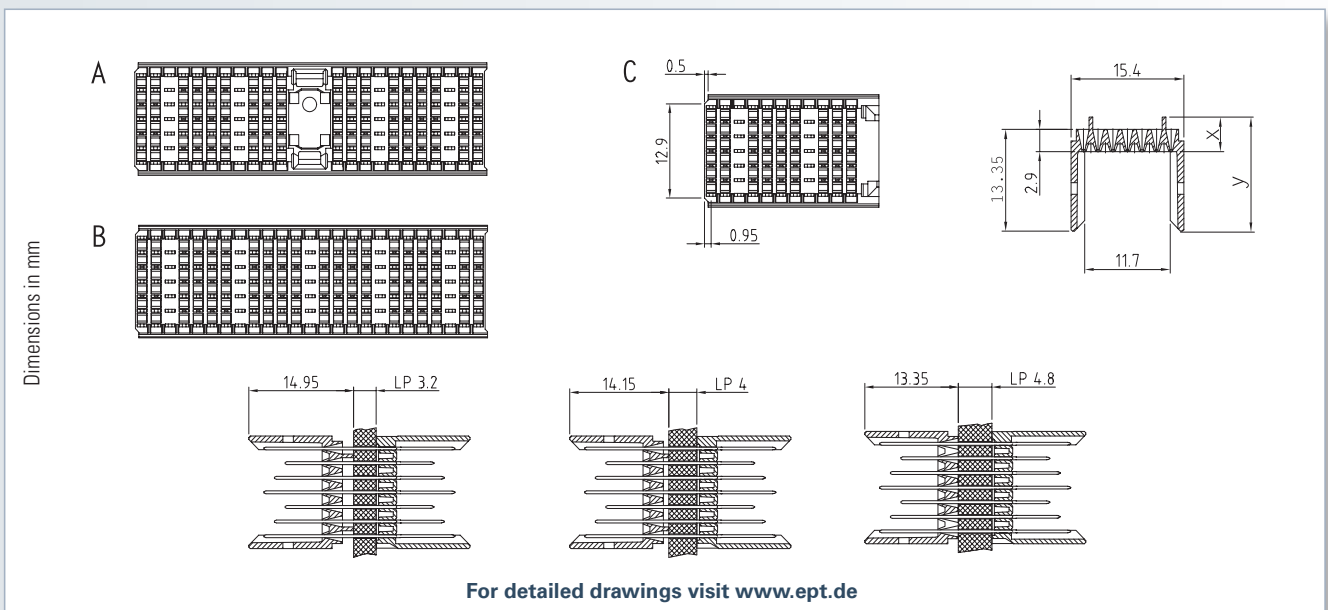

PCB thickness	X	Y	Part number		PU (Bulk)	Part number B22	PU (Bulk)	Part number B19	PU (Bulk)	Part number C	PU (Bulk)
			A	B							
< 2.4 mm	6.3 mm	16.75 mm	243-5525-5/1	243-5625-5/1	750	243-5622-5/1	850	243-5619-5/1	1000	243-5511-5/1	1800
2.4 – 3.2 mm	4.9 mm	15.35 mm	243-5525-4/1	243-5625-4/1		243-5622-4/1		243-5619-4/1		243-5511-4/1	
3.2 – 4.0 mm	4.5 mm	14.95 mm	243-5525-1/1	243-5625-1/1		243-5622-1/1		243-5619-1/1		243-5511-1/1	
4.0 – 4.8 mm	3.7 mm	14.15 mm	243-5525-2/1	243-5625-2/1		243-5622-2/1		243-5619-2/1		243-5511-2/1	
> 4.8 mm	2.9 mm	13.35 mm	243-5525-3/1	243-5625-3/1		243-5622-3/1		243-5619-3/1		243-5511-3/1	

On request

- different designs and special types

Application:

compatible with all male connectors with transfer zone

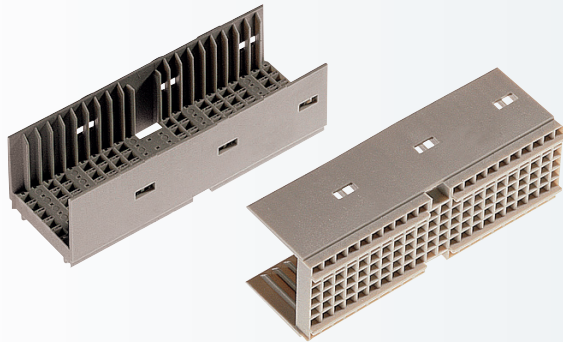

Type: Shroud
Pitch: 2 mm
Packaging: Bulk
Standard: IEC 61076-4-101



Technical Specifications on page 12

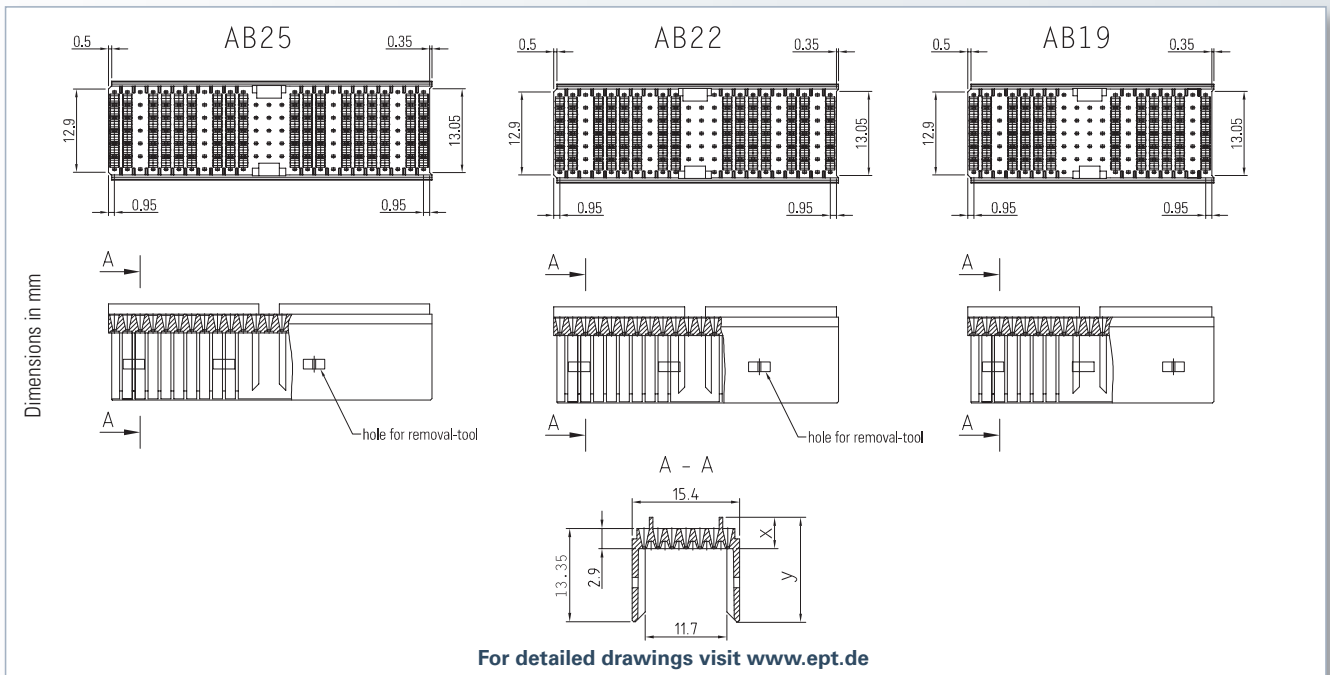

PCB thickness	X	Y	Part number		PU (Bulk)	Part number		PU (Bulk)	Part number		PU (Bulk)
			AB25			AB22 (cPCI RP 5)			AB19 (cPCI RP 3)		
< 2.4 mm	6.3 mm	16.75 mm	243-5725-5/1		750	243-5722-5/1		850	243-5719-5/1	1000	
2.4 – 3.2 mm	4.9 mm	15.35 mm	243-5725-4/1			243-5722-4/1			243-5719-4/1		
3.2 – 4.0 mm	4.5 mm	14.95 mm	243-5725-1/1			243-5722-1/1			243-5719-1/1		
4.0 – 4.8 mm	3.7 mm	14.15 mm	243-5725-2/1			243-5722-2/1			243-5719-2/1		
> 4.8 mm	2.9 mm	13.35 mm	243-5725-3/1			243-5722-3/1			243-5719-3/1		

On request

- different designs and special types

Application

compatible with all male connectors with transfer zone



Coding keys

Male connector				PU (Bulk)
Coding key	Code No.	Color	Part number	
	1236	Nut brown RAL 8011	243-8011	1000
	1248	Strawberry red RAL 3018 Telephony Spec	243-8012	
	1356	Blue lilac RAL 4005	243-8013	
	1567	Brilliant blue RAL 5007 5.0 V cPCI	243-8014	
	2578	Reseda green RAL 6011	243-8021	
	3456	Rape yellow RAL 1021 3.3 V cPCI	243-8031	
	3467	Slate gray RAL 7015	243-8032	
	3478	Steel blue RAL 5011	243-8033	
	3568	Pastel orange RAL 2003	243-8034	
	4678	Ocher yellow RAL 1024	243-8041	

Female connector				PU (Bulk)
Coding key	Code No.	Color	Part number	
	4578	Nut brown RAL 8011	244-8011	1000
	3567	Strawberry red RAL 3018 Telephony Spec	244-8012	
	2478	Blue lilac RAL 4005	244-8013	
	2348	Brilliant blue RAL 5007 5.0 V cPCI	244-8014	
	1346	Reseda green RAL 6011	244-8021	
	1278	Rape yellow RAL 1021 3.3 V cPCI	244-8031	
	1258	Slate gray RAL 7015	244-8032	
	1256	Steel blue RAL 5011	244-8033	
	1247	Pastel orange RAL 2003	244-8034	
	1235	Ocher yellow RAL 1024	244-8041	



ept connectors

Product Samples

Fast and Simple

You can receive product samples from ept quickly, easily and free of charge. Either with a few easy steps on www.ept.de or by contacting us directly under +49-8861-2501-0 (recommended for special features, such as modifications).

For detailed coordination as well as individual consultation, you can choose between our sales representative in your area, our service representative in Peiting or a local sales partner or distributor.

Order your product samples here:

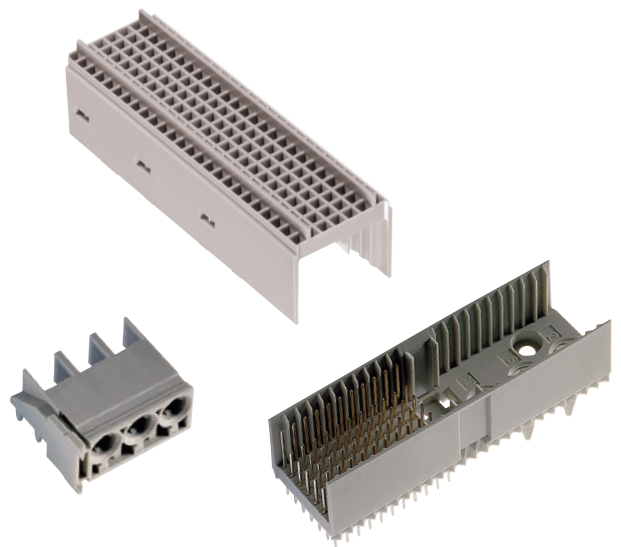

One Stop Supplier

ept is a German quality supplier with sophisticated products in the field of electrical connectivity. Our products and capabilities are used in high-quality and demanding applications such as industrial automation, healthcare, measurement and traffic technology as well as automotive electronics.

At six locations worldwide, connectors are manufactured in-house using highly automated processes across four manufacturing steps (stamping, electroplating injection molding and assembly). Over five decades, we have formed trusting and successful partnerships with our customers, who are at the center of everything we do.

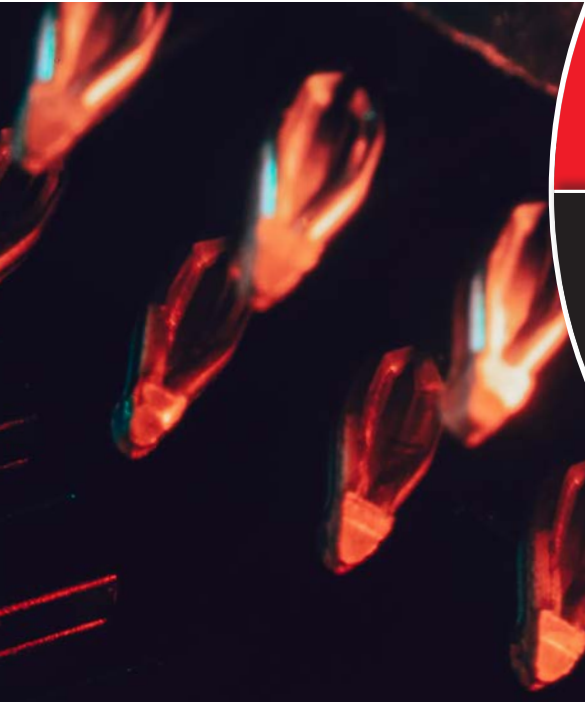



ept GmbH

tel. +49 (0) 8861 / 2501 0

fax +49 (0) 8861 / 5507

sales@ept.de

Bergwerkstr. 50

86971 Peiting, Germany

Other Locations

Buching, Germany

Augsburg, Germany

Habartov, Czech Republic

South Chesterfield, USA

Shanghai, China

Distributors Worldwide

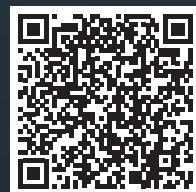

The information contained, including drawings and illustrations intended for illustrative purposes only, is deemed reliable. ept does not, however, guarantee its accuracy or completeness and disclaims any liability in connection with its use. ept's obligations are limited to the information contained in the General Terms and Conditions of Sale, which are available at www.ept.de.

Users of ept's products should determine through a self-performed evaluation whether the products used are suitable for the intended application in each case.