

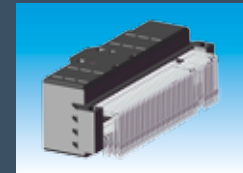

Press-fit Technology from one Source

As „One-Stop-Supplier“ ept offers you long time experience in press-fit technology of more than 25 years. ept's comprehensive knowledge and experience offer a great foundation for the development of cost-optimized connector products - from development including the building of prototypes, over manufacturing of equipment and tools, up to serial production.

Automotive



High-Density Terminals

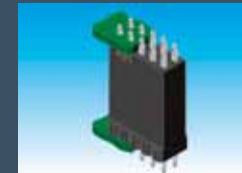

PCB Connectors with Double-Tcom

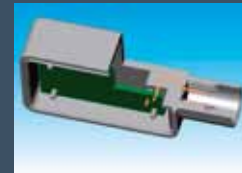

Overmolded Connectors (Hybrid)



Stamped Contacts



Pin Header

Automation



DIN 41612 for robust Signal- and Power-Connections

Measuring

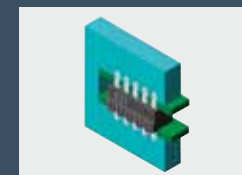

flexilink for PCB-Stacking: reliable mechanical and electrical Connections in demanding Environments

Medical Technology



PC/104-Plus for multiple PCB-Stacking

Telecommunication



Micro-TCA Backplane Direct Connector for High-Speed Applications up to 12,5 Gbit/s

LED Technology

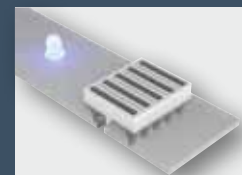

flexilink^{lumper} for easy PCB-Chaining without Soldering

Our Performances

With 800 employees and a global network of own production facilities ept as a family owned company offers you highest quality standards and reliability for your press-fit project - all from one source.

Task
Design Simultaneous engineering
Tool shop Molding tools, stamping dies, samples, prototyping
Production Stamping, reel-to-reel plating, injection molding, assembling
Product and / or applications Connectors, tools, processing equipment
Result

- Wide range of qualified and well-proven press-fit zones for hole diameters from 0,56 mm up to 2 mm
- Support for development of high-quality and cost-optimized designs
- Distinct project management according to TS 16949
- Production of functional prototypes and pre-production samples
- Inhouse construction and production of stamping and injection molding tools as well as equipment for assembly, inspection and packaging
- High-quality production of serial parts at own stamping shop, reel-to-reel electroplating, injection molding and assembly
- Global network of own production facilities with maximum production security
- Wide range of press-fit machines and tools

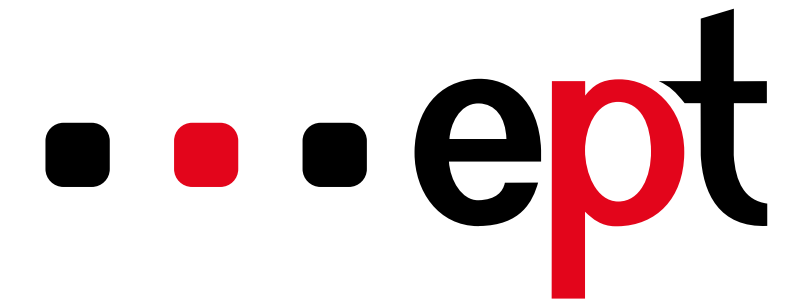

electronic precision technology

Press-fit Technology with Tcom press®



Press-fit Machines and Tools

As a perfect addition ept offers competent support for the processing of press-fit connectors on PCB. In addition to a wide spectrum of press-fit machines and tools we offer the development and execution of customized machines and equipment. As a result, the optimal design of connectors, press-fit zone, assembly tools, process and machine leads to a smooth and sound solution for your press-fit project.



We are looking forward to your request. Please visit our homepage www.ept.de.

ept GmbH
Bergwerkstr. 50
86971 Peiting, Germany
Tel. +49 (0) 88 61 25 01 0
Fax +49 (0) 88 61 55 07
sales@ept.de
www.ept.de

ept, inc.
805 Liberty Way
Chester, Virginia 23836, USA
Tel. 800 323 2568
Tel. +1 804 530 0820
Fax +1 804 530 0837
sales@eptusa.com
www.eptusa.com

ept electronic precision technology (Shanghai) Ltd.
6F Building 37, No. 333 Qin Jiang Road
Shanghai, P. R. China
Post code: 20 02 33
Tel. +86 (0) 21-54 26-09 88
Fax +86 (0) 21-64 95-39 49
sales@eptcn.com
www.eptcn.com



- Design
- Advantages
- Quality Features
- Applications



Reliable electrical and mechanical Connections

Press-fit technology has evolved over three decades to what it is today: a widely recognized, solderless connection between electrical contacts and plated through holes of a PCB, applied in various applications.

Key Components:

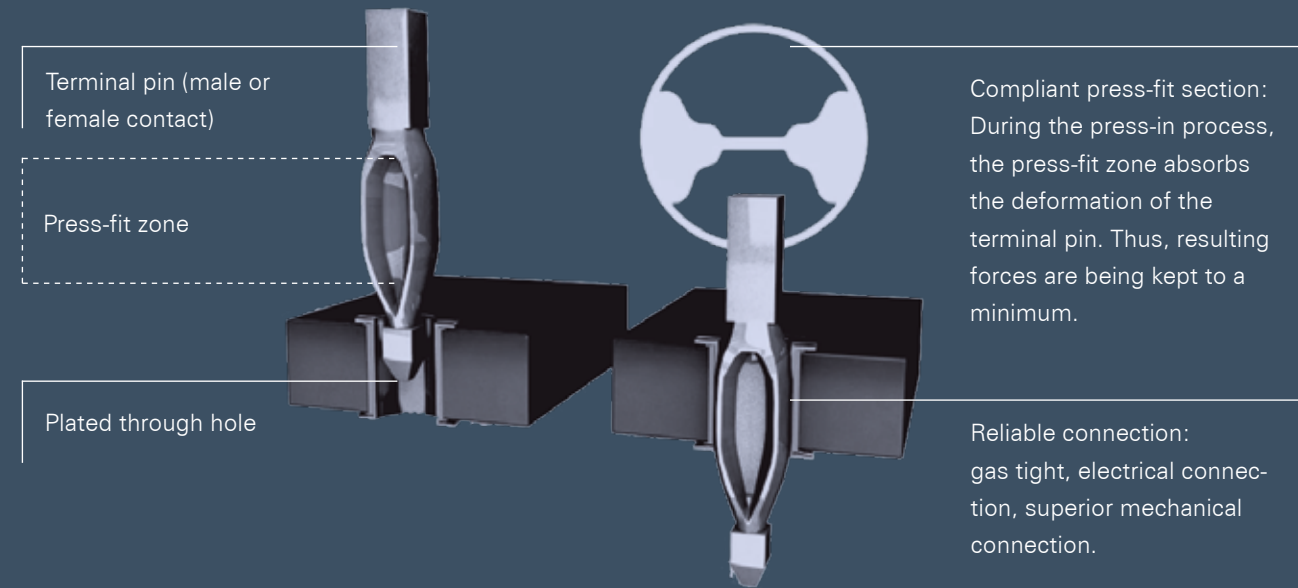

Advantages of Press-fit Technology compared to Soldering Technology

✓ Performance

- Highest reliability and longevity
- Mechanical carrying capacity
- Better resistance to shock and vibration
- Temperature range from -40°C up to +150°C
- Long term durability
- Gas tight, reliable connection
- Prevention of thermal stress on the PCB and adjacent components
- Avoidance of cold solder joints

✓ Cost Savings

- Cost effective assembling on the PCB, also on the back-side
- Repairability (up to three times)
- Fast and reliable manufacturing process

✓ Design

- Simple processing
- Enables new design possibilities for your application
- No restriction of PCB size or thickness
- Processing of multilayer boards in varying thickness possible
- Mixed assembly possible (together with solder technology)

✓ Environment

- In accordance to RoHS and WEEE
- No soldering fumes and flux residues on the PCB
- Prevention of pollutive substances
- No need to wash PCBs

A reliable press-fit connection can be guaranteed only, if each of the four pillars in press-fit technology is taken into account closely:

- **Press-fit zone:**
Dimensions and tolerances, surface structure, design, and hole specification
- **Application:**
Application (such as automotive), implementation (such as pin header for cable connection), design, material specification, and manufacturing process
- **PCB:**
Surface material and PCB holes
- **Processing equipment:**
Proper and reliable press-fit process including effective and efficient quality control features

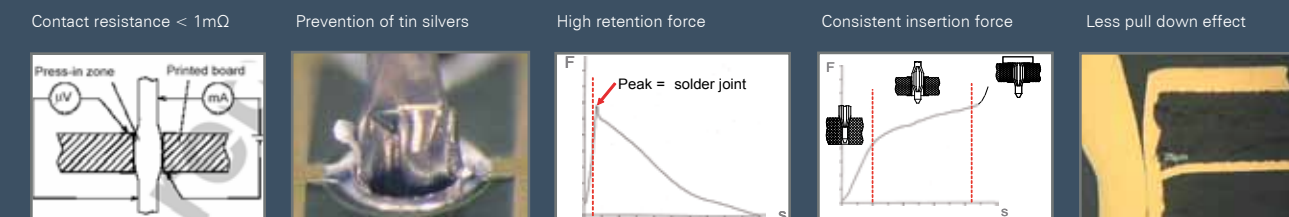
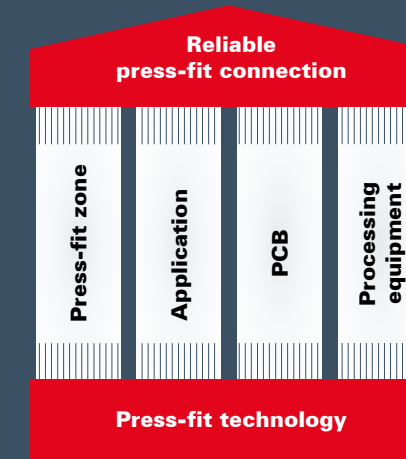

Quality Features of ept's Press-fit Section Tcom press®

With ept as partner in your press-fit technology project, you can count on broad knowledge and highest experience, especially in the subareas of **press-fit zone** and **processing equipment**.

The subareas of **application** and **PCB** are covered with more than 25 years of experience and Know-How thru numerous project in many different industries such as automotive, industrial, telecom, medical, military and others. Our professional project management with committed and experienced employees will lead your press-fit project to a success, as we have proven for the benefit of many customers.

- High retention force in both, max. hole and min. hole diameter
- Low hole deformation thru perfect deformation features of the compliant section
- Prevention of tin slivers
- Little pull down effect (or jet effect)
- No pin rotation thru symmetrical design
- Low contact resistance
- Scalable in each dimension, thus, easy adaptation for various applications ranging from high current to high-speed
- High resistance and robustness concurrently with excellent deformation characteristics
- Consistent insertion force in both, max. hole and min. hole diameter
- Proper and reliable processability thru elaborate processing features
- Highest reliability in stamping thru coined shape
- Video control of quality features in mass production
- Meets highest requirements with leading OEMs in the automotive industry
- 0 field-failures with billions of press-fit zones supplied

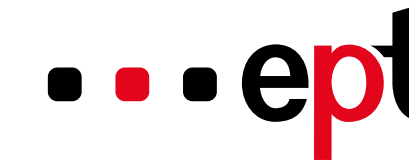

ept offers the best design solutions for your requirements.

Appropriate PCBs for Press-fit Applications

	PCB hole plating				
	imm. Sn	imm. NiAu	imm. Ag	Cu passivated	HAL lead free
Plating thickness	0,8 - 1,2 μm	5 μm Ni 0,1 μm Au	0,1 - 0,2 μm	0,1 - 0,5 μm	>5 bis 50 μm
Suitability for press-fit technology	excellent	limited*	fair	fair	limited*

*depending on application

Contact Reliability

A high quality press-fit connection provides highest reliability for your application. ept's press-fit zone Tcom press® has been applied successfully for years in safety-relevant applications, such as ABS systems. As best-in-class, Tcom press® has also proven itself in applications under extreme environmental impact, such as multible variations in temperature from -40°C up to +150°C. We look forward to meeting your challenges.

	Conductor cross-section in mm²	Failures in fit ¹⁾
Wire wrap	0,05 to 0,5	0,002
Press-fit	0,3 to 6	0,005
Soldering - manually / automated	-	0,5 / 0,05
IDC (insulation displacement)	0,05 to 2	0,05
SMD soldering	-	0,2
Crimp - manually / automated	0,05 to 10	0,25
Screw	0,5 to 32	0,5

¹⁾ 1 fit equals 1 x 10⁻⁹ of failures per hour. This means one failure during 10⁹ operation hours of the component.

We offer a variety of different press-fit zones in terms of size, shape, and material specification.

Please ask for details about our choices of different press-fit zones. We are pleased to support you.

Phone +49 (0) 88 61 25 01 0
E-Mail sales@ept.de