

Product Information

ingun Prüfmittelbau GmbH
Max-Stromeyer-Straße 162
78467 Konstanz
Germany

Tel. +49 7531 8105-0
Fax +49 7531 8105-65
info@ingun.com
www.ingun.com

INGUN Marking Unit

Compact Unit - powered with compressed air for special applications

The INGUN Marking Unit is used to mark „good“ tested PC Boards. It is powered by means of compressed air.

An electrical impulse signal activates a free positional solenoid valve. The applied compressed air is then passed onto the drive unit of the Marking Unit. The graving tool receives a combined rotating / stroke movement, is then pushed against the PC Board - and marks the PC Board with a permanent circle of 2 mm diameter.

The compact design of the Marking Unit allows space-saving assembly in the test fixture. The separation of the drive unit and the Marking Unit itself minimizes the influence of electro-magnetic interference fields both on the PC Board as well as in regard to the measurement signal.

The mounting of the Marking Unit can be carried out either with the outside thread MF 16x1, or on the shaft of the Unit with either the \varnothing 12 mm or \varnothing 4.5 mm section.



Technical Data:

Marking Unit	
Recommended Working Stroke:	+ 2.0 mm
Maximum Working Stroke:	+ 3.8 mm
Marking:	\varnothing 2.0 mm Circle
Recommended marking impulse:	approx. 1 sec.
Material of engraving tool:	Hard metal
Dimensions:	\varnothing 16 mm x 53.2 (+3.8) mm
Outside thread:	MF 16x1
Compressed Air (*):	0.6 MPa

Recommended Accessories:

(stand-alone operation)	
<u>Solenoid Valve:</u>	MHE2-M1H-3/2G-QS-4-K
- Normal rated flow:	100 l/min
- Operational Voltage:	24 V DC
<u>Maintenance Unit:</u>	AW10-M5H

- *: Compressed Air:
- Filtered 5 μ m oiled or non-oiled
 - Recommended quality: ISO VG32 class 1

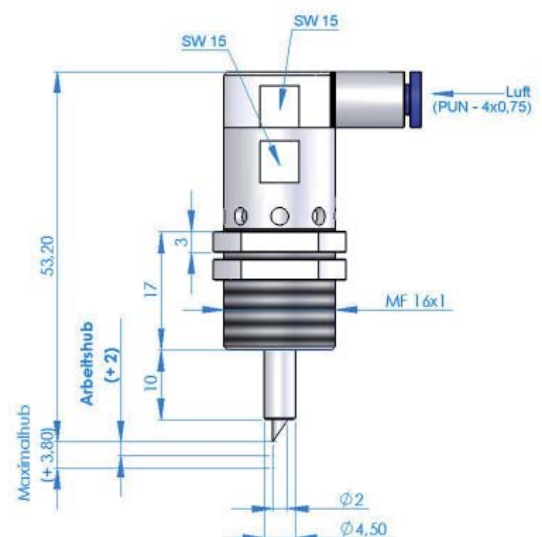

Part Nr: 25241 (without Accessories)

Prices and delivery on request.
Technical changes possible without prior notification.